



# Vane pumps single and double SDV10 - SDV20 - SDV2010 - SDV2020



Publ. 1 - EN0738 - A

06 / 2001 / FB

Replaces :

L13 - 10738 - 1

**DENISON** Hydraulics

<b>GENERAL</b>	General applications instructions . . . . .	2
	Maximum speed . . . . .	3
	Pressure ratings . . . . .	3
	Minimum allowable inlet pressure . . . . .	3
	General characteristics . . . . .	3
<b>SD V10</b>	Ordering code . . . . .	4
	Operating characteristics . . . . .	4
	Technical data . . . . .	4
	Dimensions . . . . .	5
<b>SD V20</b>	Ordering code . . . . .	6
	Operating characteristics . . . . .	6
	Technical data . . . . .	6
	Dimensions . . . . .	7
<b>SD V2010</b>	Ordering code . . . . .	8
	Operating characteristics . . . . .	8
	Technical data . . . . .	8
	Dimensions . . . . .	9
<b>SD V2020</b>	Ordering code . . . . .	10
	Operating characteristics . . . . .	10
	Technical data . . . . .	10
	Dimensions . . . . .	11
<b>GENERAL APPLICATIONS INSTRUCTIONS</b>	1. Check speed range, pressure, temperature, fluid quality, viscosity and pump rotation.	
	2. Check inlet conditions of the pump, if it can accept application requirement.	
	3. Type of shaft : if would support operating torque.	
	4. Coupling must be chosen to minimize pump shaft load (weight, misalignment).	
	5. Filtration : must be adequate for lowest contamination level.	
	6. Environment of pump : avoid noise reflection, pollution and shocks.	

## TECHNICAL DATA

### MINIMUM AND MAXIMUM SPEED, PRESSURE RATINGS

Series	Size	Theoretical Displacement Vi cm <sup>3</sup> /rev (in <sup>3</sup> /rev)	Maximum speed		Maximum pressure			
			HF-0, HF-1	HF-3, HF-4	HF-0, HF-2		HF-1, HF-4, HF-5	HF-3
			HF-2	HF-5	Int.	Cont.	Cont.	Cont.
			RPM	RPM	Bar (psi)	Bar (psi)	Bar (psi)	Bar (psi)
SDV10	1	3,3 (.20)	4200	1800	175 (2500)	160 (2250)	130 (1900)	100 (1500)
	2	6,6 (.40)	4200	1800	175 (2500)	160 (2250)	130 (1900)	100 (1500)
	3	9,8 (.60)	3900	1800	175 (2500)	160 (2250)	130 (1900)	100 (1500)
	4	13,1 (.80)	3000	1800	175 (2500)	160 (2250)	130 (1900)	100 (1500)
	5	16,4 (1.00)	2400	1800	175 (2500)	160 (2250)	130 (1900)	100 (1500)
	6	19,5 (1.19)	2100	1800	150 (2200)	140 (2000)	130 (1900)	100 (1500)
	7	22,8 (1.39)	1800	1800	140 (2000)	140 (2000)	130 (1900)	100 (1500)
SDV20	6	19,5 (1.19)	3600	1800	175 (2500)	160 (2250)	130 (1900)	110 (1600)
	7	22,8 (1.39)	2700	1800	175 (2500)	160 (2250)	130 (1900)	110 (1600)
	8	26,5 (1.62)	2400	1800	175 (2500)	160 (2250)	130 (1900)	110 (1600)
	9	29,7 (1.81)	2100	1800	175 (2500)	160 (2250)	130 (1900)	110 (1600)
	11	36,4 (2.22)	1800	1800	175 (2500)	160 (2250)	110 (1600)	100 (1400)
	12	39,0 (2.38)	1800	1800	150 (2200)	140 (2000)	110 (1600)	100 (1400)
13	42,4 (2.59)	1800	1800	150 (2200)	140 (2000)	110 (1600)	100 (1400)	

HF-0, HF-2 = Anti-wear petroleum base. HF-1 = Non anti-wear petroleum base. HF-5 = Synthetic fluids.

HF-3 = Water-in-oil invert emulsions. HF-4 = Water glycol solutions.

For further information, if the performance characteristics outlined above do not meet your own particular requirements, please consult your local DENISON Hydraulics office.

### MINIMUM ALLOWABLE INLET PRESSURE (BAR ABSOLUTE / PSI)

Series	Size	Speed RPM										Size	
		1500	1800	2100	2400	2700	3000	3300	3600	3900	4200		
SDV10	1	0,80 (11.6)	0,80 (11.6)	0,80 (11.6)	0,80 (11.6)	0,80 (11.6)	0,80 (11.6)	0,80 (11.6)	0,80 (11.6)	0,80 (11.6)	0,80 (11.6)	0,80 (11.6)	1
	2	0,80 (11.6)	0,80 (11.6)	0,80 (11.6)	0,80 (11.6)	0,80 (11.6)	0,80 (11.6)	0,80 (11.6)	0,80 (11.6)	0,80 (11.6)	0,80 (11.6)	0,80 (11.6)	2
	3	0,80 (11.6)	0,80 (11.6)	0,80 (11.6)	0,80 (11.6)	0,80 (11.6)	0,80 (11.6)	0,80 (11.6)	0,85 (12.3)	0,95 (13.8)			3
	4	0,80 (11.6)	0,80 (11.6)	0,80 (11.6)	0,80 (11.6)	0,85 (12.3)	0,95 (13.8)						4
	5	0,80 (11.6)	0,80 (11.6)	0,85 (12.3)	0,95 (13.8)								5
	6	0,80 (11.6)	0,85 (12.3)	1,00 (14.5)									6
	7	0,85 (12.3)	1,00 (14.5)										7
SDV20	6	0,80 (11.6)	0,80 (11.6)	0,80 (11.6)	0,80 (11.6)	0,80 (11.6)	0,85 (12.3)	0,95 (13.8)	1,01 (14.6)				6
	7	0,80 (11.6)	0,80 (11.6)	0,80 (11.6)	0,80 (11.6)	0,80 (11.6)							7
	8	0,80 (11.6)	0,80 (11.6)	0,85 (12.3)	0,95 (13.8)								8
	9	0,80 (11.6)	0,80 (11.6)	0,95 (13.8)									9
	11	0,80 (11.6)	0,95 (13.8)										11
	12	0,85 (12.3)	1,03 (14.9)										12
	13	0,95 (13.8)	1,05 (15.2)										13

Multiply absolute pressure by 1,25 for HF-3, HF-4 fluids.

by 1,35 for HF-5 fluids.

by 1,10 for ester or rapeseed base.

Use the cartridge with the highest absolute pressure for double pumps.

### GENERAL CHARACTERISTICS

Series	Mounting standard	Weight kg (lb)	Moment of inertia kgm <sup>2</sup> x 10 <sup>-4</sup> (lb.in <sup>2</sup> )	Port connections					
				Suction			Pressure		
Code				P	S	B	P	S	B
SDV10	SAE A	4,5 – 6,8 (10 – 15)	0,5 (0.17)	1" NPTF	1"5/16 12UNF-2B	G 1"	1/2" NPTF	3/4" 16UNF-2B	G 1/2"
SDV20	SAE A	7,3 – 8,2 (16 – 18)	2,2 (0.75)	1"1/4 NPTF	1"5/8 12UNF-2B	G 1"1/4	3/4" NPTF	1"1/16 12UNF-2B	G 3/4"
Code				F			S		
							P1*	P2**	P1-P2
SDV2010	SAE B	13,6 (30.0)	2,6 (0.90)	4 bolts flange 1"1/2 dia			1"1/16 12UNF-2B	3/4" 16UNF-2B	***
SDV2020	SAE B	15,9 (35.0)	4,3 (1.50)	4 bolts flange 2" dia			1"1/16 12UNF-2B	1"1/16 12UNF-2B	G 3/4"

\* P1 = Pressure port near the shaft

\*\* P2 = Pressure port near the cover end

\*\*\* P1 = G 3/4" P2 = G 1/2"

**Model No.**

Vane pump

Series  
10

Mounting

1 = 2-bolt flange, 3 1/4 pilot (SAE A) (standard)

Inlet port connections

P = 1" NPTF thread  
S = 1 5/16-12 UNF-2B thread  
B = G 1" (BSPP)

Ring size

(Delivery at 1200 rpm and 100 psi)

1 = 1 USgpm  
2 = 2 USgpm  
3 = 3 USgpm  
4 = 4 USgpm  
5 = 5 USgpm  
6 = 6 USgpm  
7 = 7 USgpm

SDV 10 - 1 P 5 S - 1 C L

Shaft rotation (view on shaft end)

L = Counter-clockwise  
Omit for clockwise

Position of outlet port (Viewed from cover end of pump)

A = Opposite inlet port  
B = 90° CCW from inlet  
C = In line with inlet  
D = 90° CW from inlet

Shaft

1 = Straight keyed  
11 = Splined  
38 = 11 teeth - 3/4" OD

Outlet port connections

P = 1/2" NPTF thread  
S = 3/4"-16 UNF-2B thread  
B = G 1/2" (BSPP)

**OPERATING CHARACTERISTICS**

Model Series	Ring Size	Displ. cm <sup>3</sup> /rev (in <sup>3</sup> /rev)	Max. Pressure bar (psi)	Speed RPM	Typical delivery L/min (USgpm)				Typical input power KW (hp)			
					0 bar	0 PSI	150 bar	2000 PSI	7 bar	80 PSI	175 bar	2500 PSI
SDV10	1	3,3 (.20)	175 (2500)	1200	4,0	1,0	2,0	0,5	0,07	0,09	0,71	0,96
				1500	5,0	1,3	3,0	0,8	0,09	0,12	1,08	1,44
				1800	5,9	1,6	3,9	1,0	0,10	0,14	1,44	1,93
	2	6,6 (.40)	175 (2500)	1200	7,9	2,1	5,9	1,6	0,14	0,18	2,16	2,89
				1500	9,9	2,6	7,9	2,1	0,17	0,23	2,88	3,86
				1800	11,9	3,1	9,9	2,6	0,21	0,28	3,60	4,83
	3	9,8 (.60)	175 (2500)	1200	11,8	3,1	9,8	2,6	0,20	0,27	3,56	4,77
				1500	14,7	3,9	12,7	3,4	0,26	0,34	4,63	6,21
				1800	17,6	4,7	15,6	4,1	0,31	0,41	5,70	7,65
	4	13,1 (.80)	175 (2500)	1200	15,7	4,2	12,3	3,3	0,27	0,37	4,49	6,02
				1500	19,7	5,2	16,3	4,3	0,34	0,46	5,92	7,94
				1800	23,6	6,2	20,2	5,3	0,41	0,55	7,36	9,87
	5	16,4 (1.00)	175 (2500)	1200	19,7	5,2	16,3	4,3	0,34	0,46	5,94	7,96
				1500	24,6	6,5	21,2	5,6	0,43	0,57	7,73	10,36
				1800	29,5	7,8	26,1	6,9	0,51	0,69	9,52	12,77
	6	19,5 (1.19)	152 (2200)	1200	23,4	6,2	19,2	5,1	0,41	0,55	7,00	9,39
				1500	29,3	7,7	25,1	6,6	0,51	0,68	9,13	12,25
				1800	35,1	9,3	30,9	8,2	0,61	0,82	11,27	15,11
	7	22,8 (1.39)	138 (2000)	1200	27,4	7,2	23,2	6,1	0,48	0,64	8,44	11,32
				1500	34,2	9,0	30,0	7,9	0,60	0,80	10,94	14,67
				1800	41,0	10,8	36,8	9,7	0,71	0,96	13,43	18,01

**INTERNAL LEAKAGE (TYPICAL)**

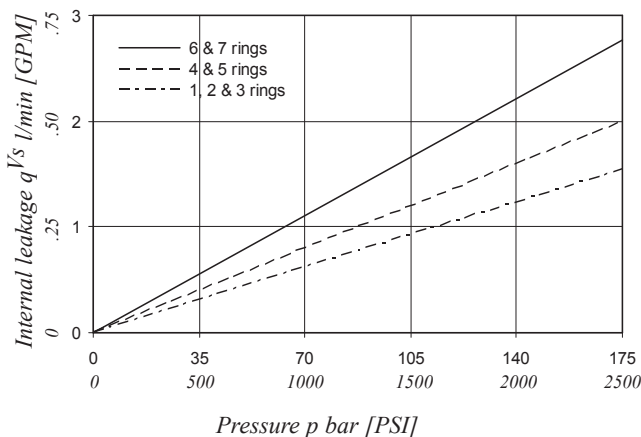

**NOISE LEVEL (TYPICAL) SDV10 - 6**

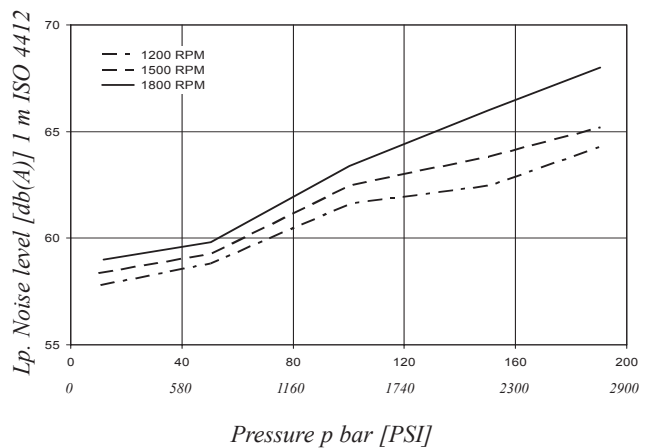

Do not operate pump more than 5 seconds at any speed or viscosity if internal leakage is higher than 50% of theoretical flow. Total leakage is the sum of each section loss at its operating conditions.

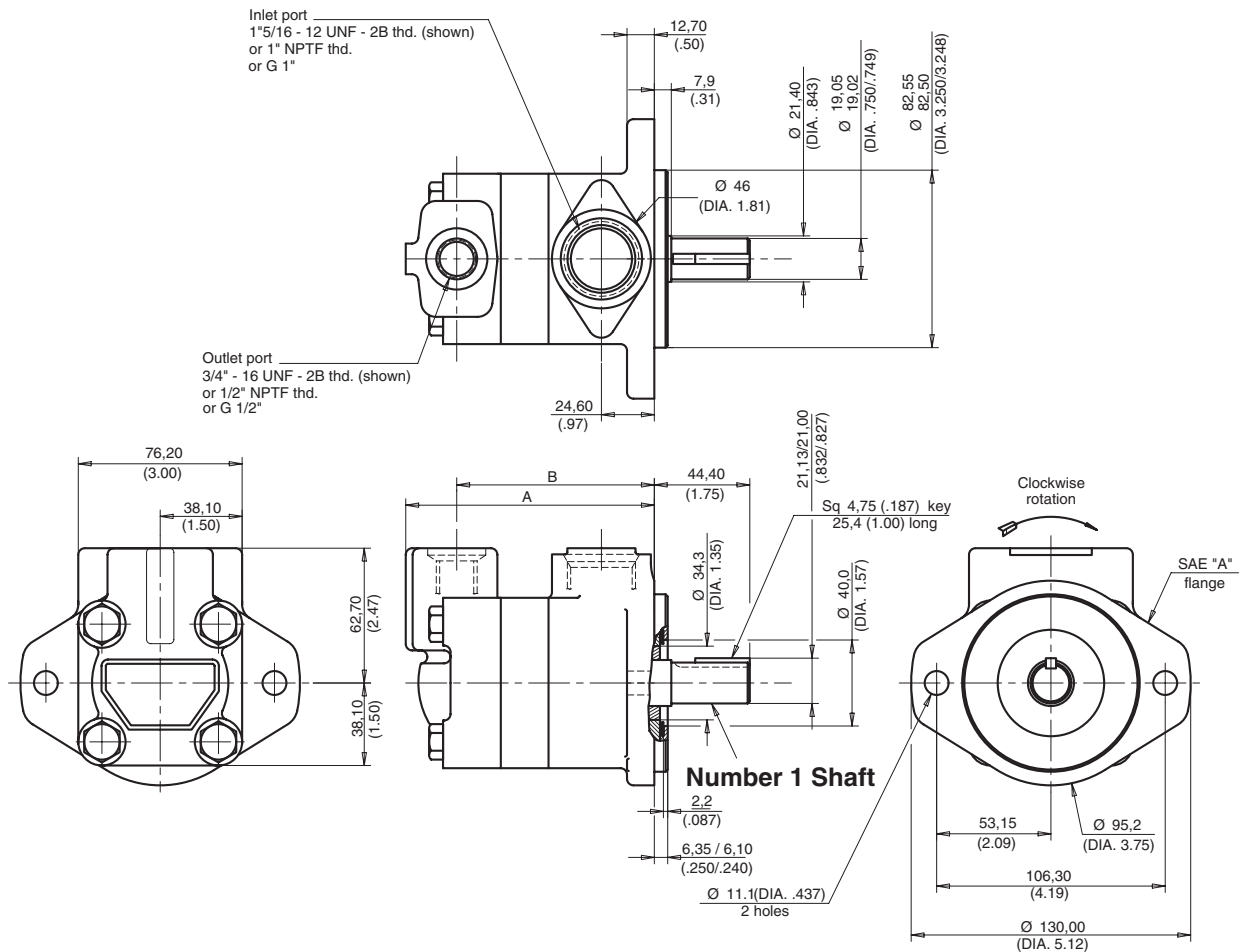

**Number 11 shaft**

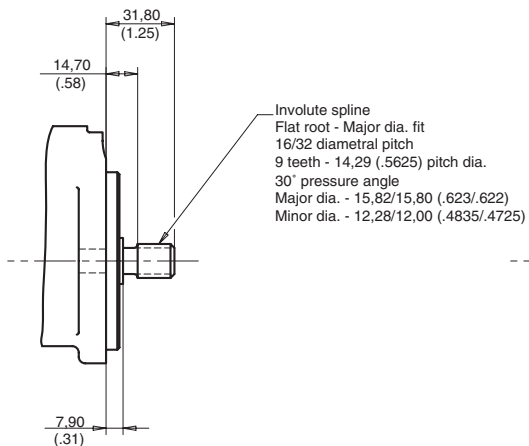

**Number 38 shaft**

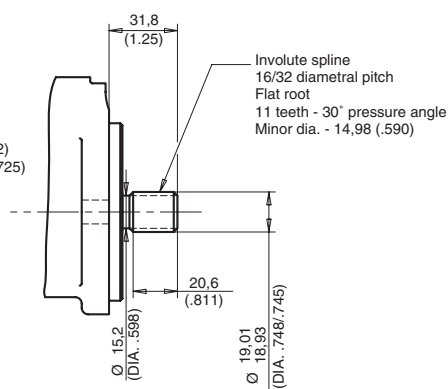

Ring size	Dimensions		Weight Kg (lb)
	A	B	
1	115,6 (4.55)	91,9 (3.62)	4,5 - (10.0)
2	115,6 (4.55)	91,9 (3.62)	4,5 - (10.0)
3	115,6 (4.55)	91,9 (3.62)	4,5 - (10.0)
4	121,9 (4.80)	98,3 (3.87)	5,6 - (12.5)
5	121,9 (4.80)	98,3 (3.87)	5,6 - (12.5)
6	127,0 (5.00)	103,4 (4.07)	6,8 - (15.0)
7	127,0 (5.00)	103,4 (4.07)	6,8 - (15.0)

Model No.

SDV 20 - 1 P 8 S - 1 C L

Vane pump

Series  
20

Mounting

1 = 2-bolt flange, 3"1/4 pilot (standard)

Inlet port connections

P = 1"1/4 NPTF thread  
S = 1"5/8 - 12 UNF-2B thread  
B = G 1"1/4 (BSPP)

Ring size

(Delivery at 1200 rpm and 100 psi)

6 = 6 USgpm  
7 = 7 USgpm  
8 = 8 USgpm  
9 = 9 USgpm  
11 = 11 USgpm  
12 = 12 USgpm  
13 = 13 USgpm

Shaft rotation (view on shaft end)

L = Counter-clockwise  
Omit for clockwise

Position of outlet port (Viewed from cover end of pump)

A = Opposite inlet port  
B = 90° CCW from inlet  
C = In line with inlet  
D = 90° CW from inlet

Shaft

1 = Straight keyed  
11 = Splined  
38 = 11 teeth - 3/4" OD  
62 = Splined

Outlet port connections

P = 3/4" NPTF thread  
S = 1"1/16 - 12 UNF-2B thread  
B = G 3/4" (BSPP)

OPERATING CHARACTERISTICS

Model Series	Ring Size	Displ. cm <sup>3</sup> /rev (in <sup>3</sup> /rev)	Max. Pressure bar (psi)	Speed RPM	Typical delivery L/min (USgpm)				Typical input power KW (hp)			
					0 bar	0 PSI	150 bar	2000 PSI	7 bar	80 PSI	175 bar	2500 PSI
SDV20	6	19,5 (1.19)	175 (2500)	1200	23,40	6,18	19,80	5,23	0,4	0,5	6,8	9,1
				1500	29,25	7,73	25,65	6,78	0,5	0,6	8,8	11,8
				1800	35,10	9,27	31,50	8,32	0,5	0,7	10,8	14,5
	7	22,8 (1.39)	175 (2500)	1200	27,36	7,23	21,96	5,80	0,4	0,6	7,5	10,1
				1500	34,20	9,04	28,80	7,61	0,5	0,7	9,9	13,3
				1800	41,04	10,84	35,64	9,42	0,6	0,9	12,2	16,4
	8	26,5 (1.62)	175 (2500)	1200	31,80	8,40	26,40	6,97	0,5	0,7	9,1	12,1
				1500	39,75	10,50	34,35	9,08	0,6	0,8	11,8	15,8
				1800	47,70	12,60	42,30	11,18	0,7	1,0	14,5	19,5
	9	29,7 (1.81)	175 (2500)	1200	35,64	9,42	30,24	7,99	0,6	0,7	10,4	13,9
				1500	44,55	11,77	39,15	10,34	0,7	0,9	13,4	18,0
				1800	53,46	14,12	48,06	12,70	0,8	1,1	16,5	22,1
	11	36,4 (2.22)	175 (2500)	1200	43,68	11,54	40,28	10,64	0,7	0,9	13,8	18,5
				1500	54,60	14,43	51,20	13,53	0,8	1,1	17,6	23,6
				1800	65,52	17,31	62,12	16,41	1,0	1,4	21,3	28,6
	12	39,0 (2.38)	152 (2200)	1200	46,80	12,36	42,60	11,25	0,7	1,0	14,6	19,6
				1500	58,50	15,46	54,30	14,35	0,9	1,2	18,6	25,0
				1800	70,20	18,55	66,00	17,44	1,1	1,5	22,6	30,4
	13	42,4 (2.59)	152 (2200)	1200	50,88	13,44	46,68	12,33	0,8	1,1	16,0	21,5
				1500	63,60	16,80	59,40	15,69	1,0	1,3	20,4	27,3
				1800	76,32	20,16	72,12	19,05	1,2	1,6	24,7	33,2

INTERNAL LEAKAGE (TYPICAL)

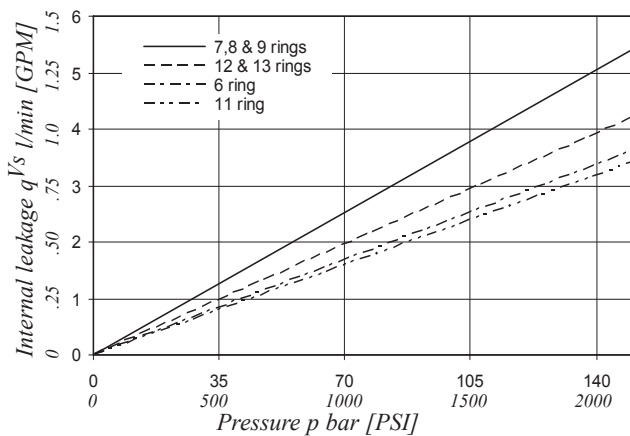

NOISE LEVEL (TYPICAL)  
SDV20 - 13

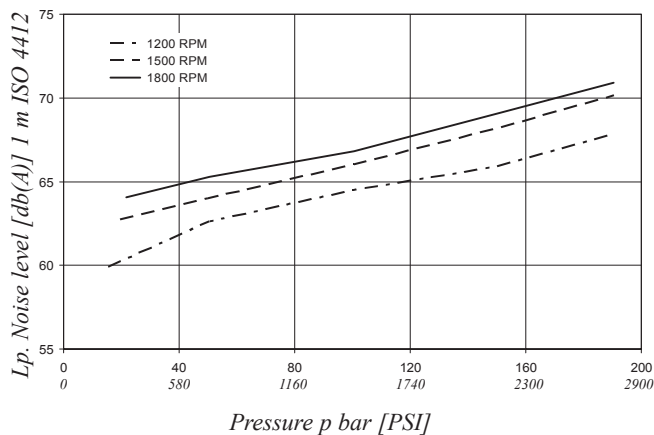

Do not operate pump more than 5 seconds at any speed or viscosity if internal leakage is higher than 50% of theoretical flow. Total leakage is the sum of each section loss at its operating conditions.

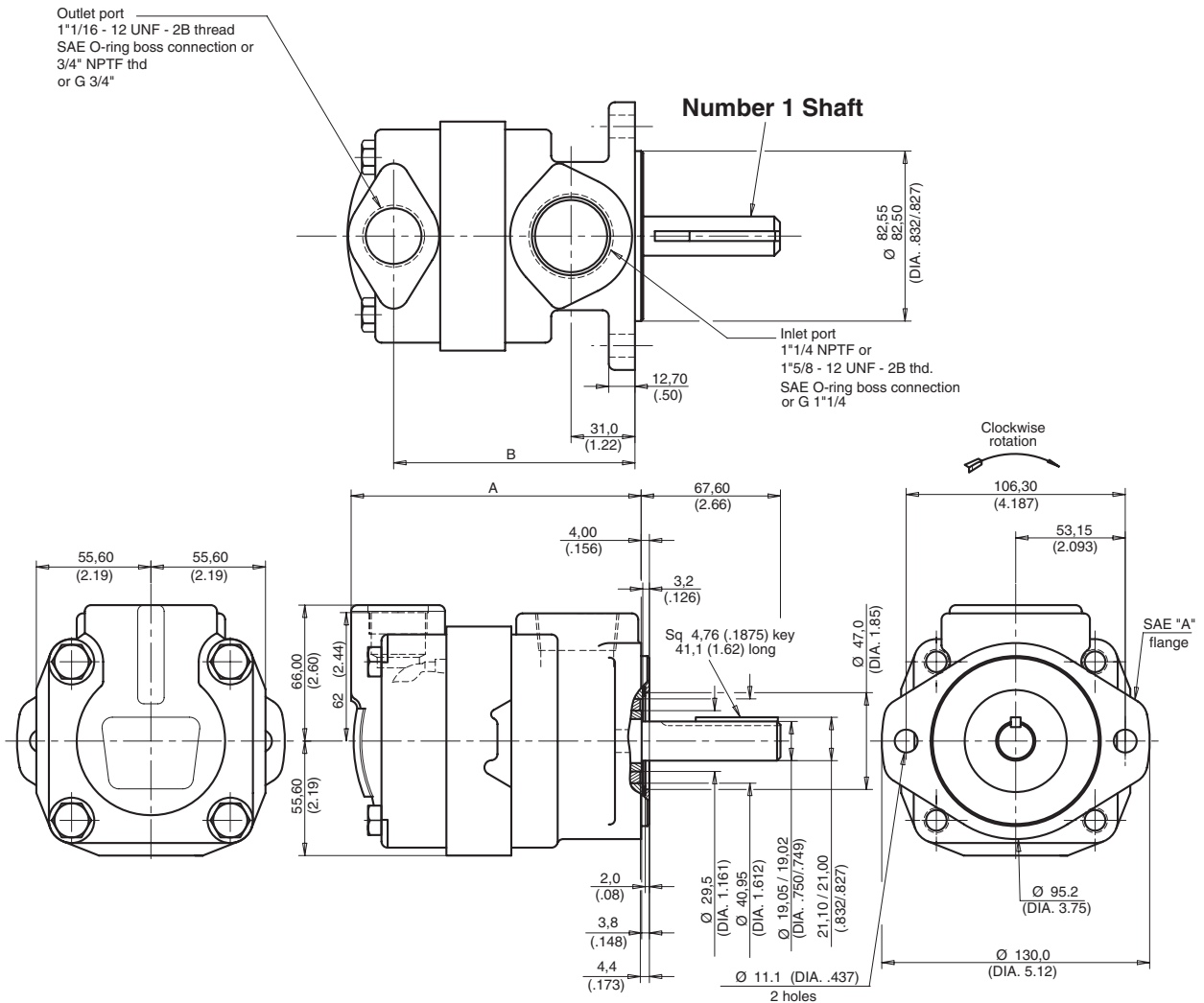

**Number 11 shaft**

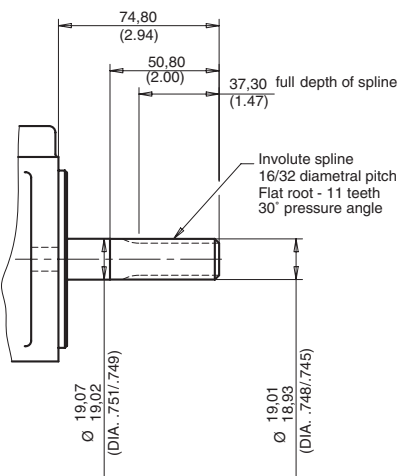

**Number 62 shaft**

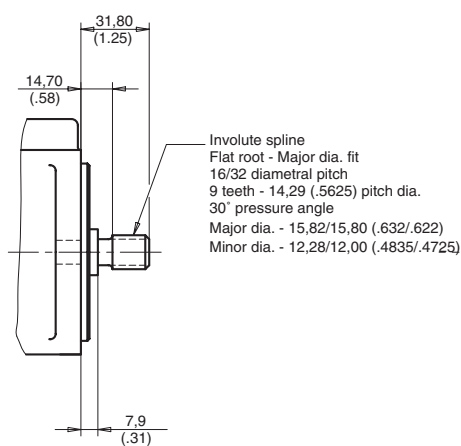

**Number 38 shaft**

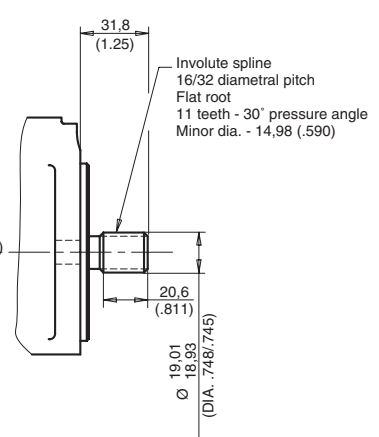

Ring size	Dimensions		Weight Kg (lb)
	A	B	
6	125,2 (4.93)	102,1 (4.02)	7,3 - (16.0)
7	131,6 (5.18)	108,4 (4.27)	7,7 - (17.0)
8	131,6 (5.18)	108,4 (4.27)	7,7 - (17.0)
9	131,6 (5.18)	108,4 (4.27)	7,7 - (17.0)
11	136,6 (5.38)	113,5 (4.47)	8,0 - (17.5)
12	140,2 (5.52)	117,1 (4.61)	8,2 - (18.0)
13	140,2 (5.52)	117,1 (4.61)	8,2 - (18.0)

**Model No.**

**SDV 2010 - 1 F 13 S 3 S - 1 CC - L**

**Vane pump**

**Series**  
2010

**Mounting**

1 = 2-bolt flange, 4" pilot (standard)

**Inlet port connections**

F = 4 bolt flange 1 1/2" dia

**Shaft-end pump ring size**

(Delivery at 1200 rpm and 100 psi)

- 6 = 6 USgpm
- 7 = 7 USgpm
- 8 = 8 USgpm
- 9 = 9 USgpm
- 11 = 11 USgpm
- 12 = 12 USgpm
- 13 = 13 USgpm

**No 1 outlet port (shaft end)**

- S = 1 1/16 - 12 UNF-2B thd
- B = G 3/4" (BSPP)

**Cover-end pump ring size**

(Delivery at 1200 rpm and 100 psi)

- 1 = 1 USgpm
- 2 = 2 USgpm
- 3 = 3 USgpm
- 4 = 4 USgpm
- 5 = 5 USgpm
- 6 = 6 USgpm
- 7 = 7 USgpm

**Shaft rotation (view on shaft end)**

- L = Left hand for counter-clockwise
- Omit for right hand

**Position of outlet port (Viewed from cover end of pump)**

**With n°1 outlet opposite inlet**

- AA = N° 2 outlet 135° CCW from inlet
- AB = N° 2 outlet 45° CCW from inlet
- AC = N° 2 outlet 45° CW from inlet
- AD = N° 2 outlet 135° CW from inlet

**With n°1 outlet 90° CCW from inlet**

- BA = N° 2 outlet 135° CCW from inlet
- BB = N° 2 outlet 45° CCW from inlet
- BC = N° 2 outlet 45° CW from inlet
- BD = N° 2 outlet 135° CW from inlet

**With n°1 outlet in line with inlet**

- CA = N° 2 outlet 135° CCW from inlet
- CB = N° 2 outlet 45° CCW from inlet
- CC = N° 2 outlet 45° CW from inlet
- CD = N° 2 outlet 135° CW from inlet

**With n°1 outlet 90° CW from inlet**

- DA = N° 2 outlet 135° CCW from inlet
- DB = N° 2 outlet 45° CCW from inlet
- DC = N° 2 outlet 45° CW from inlet
- DD = N° 2 outlet 135° CW from inlet

**Shaft**

- 1 = Straight keyed
- 11 = Splined

**N° 2 outlet port (cover end)**

- S = 3/4"-16 UNF-2B thread
- B = G 1/2" (BSPP)

**OPERATING CHARACTERISTICS**

Model Series	Ring Size	Displ. cm <sup>3</sup> /rev (in <sup>3</sup> /rev)	Max. Pressure bar (psi)
P1	6	19,5 (1.19)	175 (2500)
	7	22,8 (1.39)	175 (2500)
	8	26,5 (1.62)	175 (2500)
	9	29,7 (1.81)	175 (2500)
	11	36,4 (2.22)	175 (2500)
	12	39,0 (2.38)	152 (2200)
P2	13	42,4 (2.59)	152 (2200)
	1	3,3 (.20)	175 (2500)
	2	6,6 (.40)	175 (2500)
	3	9,8 (.60)	175 (2500)
	4	13,1 (.80)	175 (2500)
	5	16,4 (1.00)	175 (2500)
	6	19,5 (1.19)	152 (2200)
7	22,8 (1.39)	138 (2000)	

Please refer to page 6

Please refer to page 4



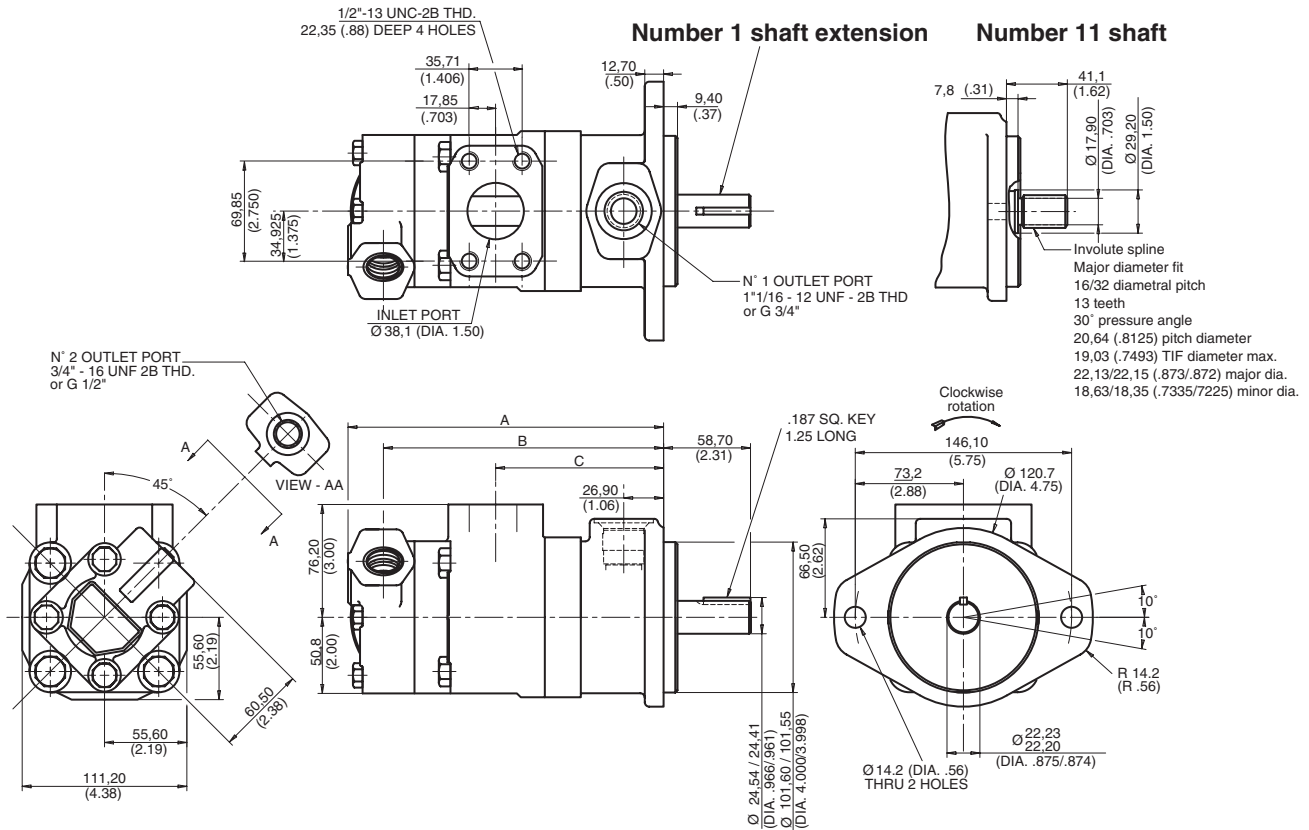

Rated Delivery, gpm @ 1200 rpm & 100 psi		Dimensions			Weight Kg (lb)
Shaft end	Cover end	A	B	C	
7, 8 or 9	1, 2 or 3	213,1 (8.39)	189,2 (7.45)	113,3 (4.46)	13,6 (30)
7, 8 or 9	4 or 5	219,5 (8.64)	195,6 (7.70)	113,3 (4.46)	
7, 8 or 9	6 or 7	224,5 (8.84)	200,7 (7.90)	113,3 (4.46)	
11	1, 2 or 3	218,2 (8.59)	194,3 (7.65)	118,1 (4.65)	
11	4 or 5	224,5 (8.84)	200,7 (7.90)	118,1 (4.65)	
11	6 or 7	229,6 (9.04)	205,7 (8.10)	121,7 (4.79)	
12 or 13	1, 2 or 3	221,7 (8.73)	197,9 (7.79)	121,7 (4.79)	
12 or 13	4 or 5	227,8 (8.97)	204,0 (8.03)	121,7 (4.79)	
12 or 13	6 or 7	232,9 (9.17)	209,0 (8.23)	121,7 (4.79)	

**INTERNAL LEAKAGE (TYPICAL)**

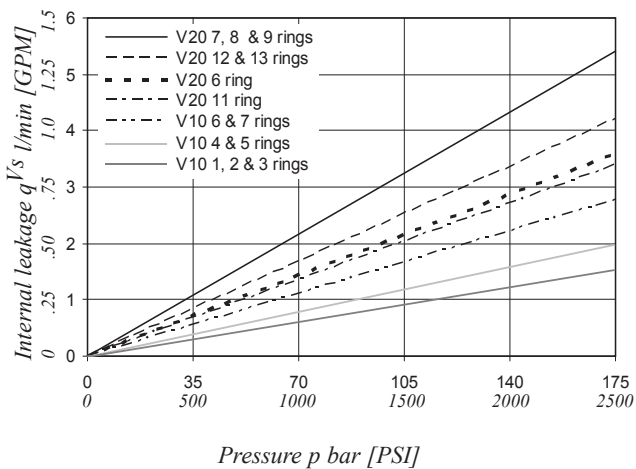

Do not operate pump more than 5 seconds at any speed or viscosity if internal leakage is higher than 50% of theoretical flow. Total leakage is the sum of each section loss at its operating conditions.

**NOISE LEVEL (TYPICAL)  
SDV2010 - 13 - 6**

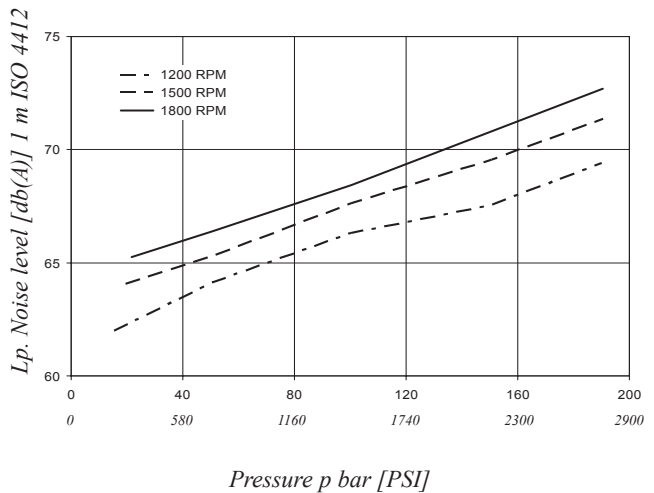

Double pump noise level is given with each section discharging at the pressure noted on the curve.

**Model No.**

**SDV 2020 - 1 F 13 S 8 S - 1 CC - L**

**Vane pump**

**Series**  
2020

**Mounting**

1 = 2-bolt flange, 4" pilot (standard)  
6 = 2-bolt flange, 3"1/4 pilot (optional)

**Inlet port connections**

F = 4 bolt flange 2.00 dia

**Shaft-end pump ring size**

(Delivery at 1200 rpm and 100 psi)

6 = 6 USgpm  
7 = 7 USgpm  
8 = 8 USgpm  
9 = 9 USgpm  
11 = 11 USgpm  
12 = 12 USgpm  
13 = 13 USgpm

**No 1 outlet port (shaft end)**

S = 1"1/16 - 12 UNF-2B thd  
B = G 3/4" (BSPP)

**Cover-end pump ring size**

(Delivery at 1200 rpm and 100 psi)

6 = 6 USgpm  
7 = 7 USgpm  
8 = 8 USgpm  
9 = 9 USgpm  
11 = 11 USgpm

**Shaft rotation (view on shaft end)**

L = Left hand for counter-clockwise  
Omit for right hand

**Position of outlet port (Viewed from cover end of pump)**

**With n°1 outlet opposite inlet**

AA = N° 2 outlet opposite inlet  
AB = N° 2 outlet 90° CCW from inlet  
AC = N° 2 outlet in line with inlet  
AD = N° 2 outlet 90° CW from inlet

**With n°1 outlet 90° CCW from inlet**

BA = N° 2 outlet opposite inlet  
BB = N° 2 outlet 90° CCW from inlet  
BC = N° 2 outlet in line with inlet  
BD = N° 2 outlet 90° CW from inlet

**With n°1 outlet in line with inlet**

CA = N° 2 outlet opposite inlet  
CB = N° 2 outlet 90° CCW from inlet  
CC = N° 2 outlet in line with inlet  
CD = N° 2 outlet 90° CW from inlet

**With n°1 outlet 90° CW from inlet**

DA = N° 2 outlet opposite inlet  
DB = N° 2 outlet 90° CCW from inlet  
DC = N° 2 outlet in line with inlet  
DD = N° 2 outlet 90° CW from inlet

**Shaft**

1 = Straight keyed  
11 = Splined

**N° 2 outlet port (cover end)**

S = 1"1/16 - 12 UNF-2B thread  
B = G 3/4" (BSPP)

**OPERATING CHARACTERISTICS**

Model Series	Ring Size	Displ. cm <sup>3</sup> /rev (in <sup>3</sup> /rev)	Max. Pressure bar (psi)	Speed RPM	Typical delivery L/min (Usgpm)				Typical input power KW (hp)			
					0 bar	0 PSI	150 bar	2000 PSI	7 bar	80 PSI	175 bar	2500 PSI
P1 & P2	6	19,5 (1.19)	172 (2500)	1200	23,40	6,18	19,80	5,23	0,4	0,5	6,8	9,1
				1500	29,25	7,73	25,65	6,78	0,5	0,6	8,8	11,8
				1800	35,10	9,27	31,50	8,32	0,5	0,7	10,8	14,5
	7	22,8 (1.39)	172 (2500)	1200	27,36	7,23	21,96	5,80	0,4	0,6	7,5	10,1
				1500	34,20	9,04	28,80	7,61	0,5	0,7	9,9	13,3
				1800	41,04	10,84	35,64	9,42	0,6	0,9	12,2	16,4
	8	26,5 (1.62)	172 (2500)	1200	31,80	8,40	26,40	6,97	0,5	0,7	9,1	12,1
				1500	39,75	10,50	34,35	9,08	0,6	0,8	11,8	15,8
				1800	47,70	12,60	42,30	11,18	0,7	1,0	14,5	19,5
	9	29,7 (1.81)	172 (2500)	1200	35,64	9,42	30,24	7,99	0,6	0,7	10,4	13,9
				1500	44,55	11,77	39,15	10,34	0,7	0,9	13,4	18,0
				1800	53,46	14,12	48,06	12,70	0,8	1,1	16,5	22,1
11	36,4 (2.22)	172 (2500)	1200	43,68	11,54	40,28	10,64	0,7	0,9	13,8	18,5	
			1500	54,60	14,43	51,20	13,53	0,8	1,1	17,6	23,6	
			1800	65,52	17,31	62,12	16,41	1,0	1,4	21,3	28,6	
12	39,0 (2.38)	152 (2200)	1200	46,80	12,36	42,60	11,25	0,7	1,0	14,6	19,6	
			1500	58,50	15,46	54,30	14,35	0,9	1,2	18,6	25,0	
			1800	70,20	18,55	66,00	17,44	1,1	1,5	22,6	30,4	
13	42,4 (2.59)	152 (2200)	1200	50,88	13,44	46,68	12,33	0,8	1,1	16,0	21,5	
			1500	63,60	16,80	59,40	15,69	1,0	1,3	20,4	27,3	
			1800	76,32	20,16	72,12	19,05	1,2	1,6	24,7	33,2	

Number 11 shaft

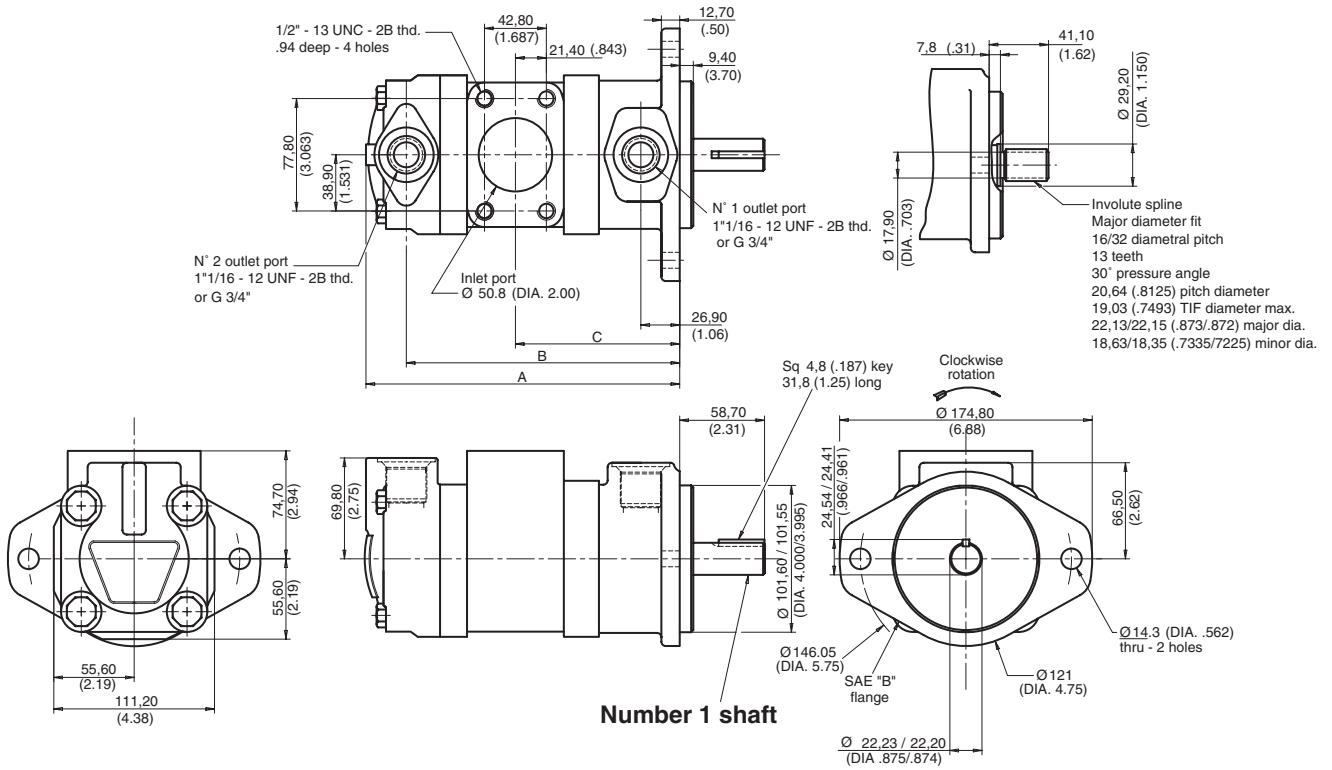

Ring size		Dimensions			Weight Kg (lb)
Shaft end	Cover end	A	B	C	
7, 8 or 9	6	213,6 (8.41)	187,7 (7.39)	114,0 (4.49)	15,9 (35)
7, 8 or 9	7, 8 or 9	220,0 (8.66)	194,0 (7.64)	114,0 (4.49)	
11	6	218,7 (8.61)	192,8 (7.59)	119,1 (4.69)	
11	7, 8 or 9	225,0 (8.86)	199,1 (7.84)	119,1 (4.69)	
11	11	229,9 (9.05)	204,0 (8.03)	119,1 (4.69)	
12 or 13	6	222,2 (8.75)	196,3 (7.73)	122,4 (4.82)	
12 or 13	7, 8 or 9	228,3 (8.99)	202,4 (7.97)	122,1 (4.82)	
12 or 13	11	233,4 (9.19)	207,5 (8.17)	122,4 (4.82)	

INTERNAL LEAKAGE (TYPICAL)

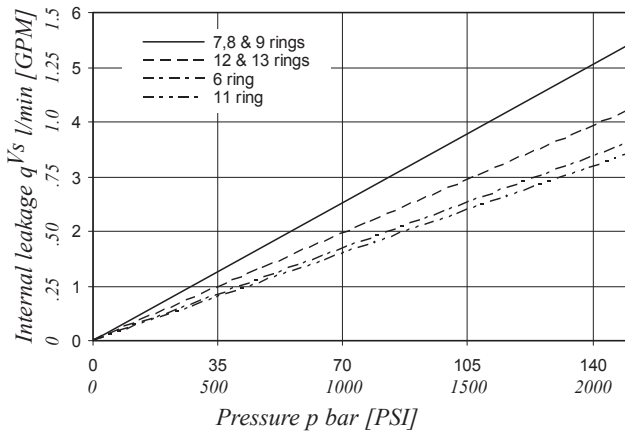

Do not operate pump more than 5 seconds at any speed or viscosity if internal leakage is higher than 50% of theoretical flow. Total leakage is the sum of each section loss at its operating conditions.

NOISE LEVEL (TYPICAL)  
SDV2020 - 13 - 11

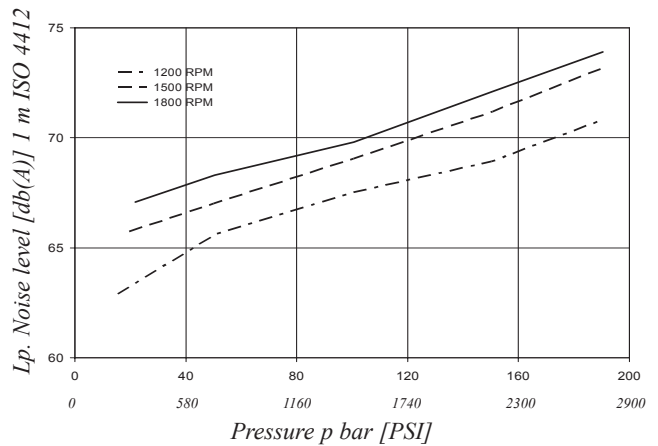

Double pump noise level is given with each section discharging at the pressure noted on the curve.