

Service Data

Vickers®

# Piston Pumps

---



## PVH57/63 Variable Displacement Piston Pump - 11 Design



Revised 11/01/97

M-2206-S

**Maximum Adjustable Stop – S Option**

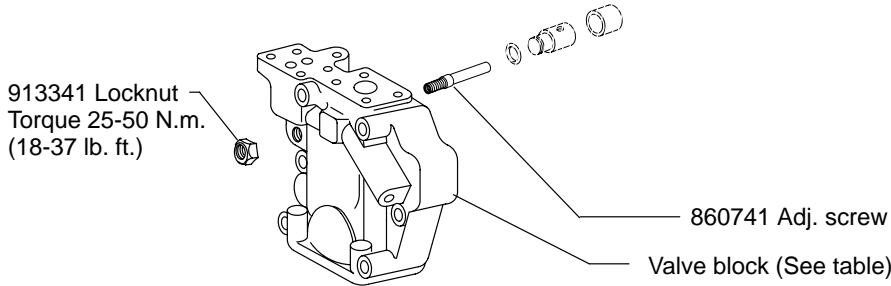

Valve Block Table

Pump Type	RH	LH
F-11-C	928631	928679
M-11-C	928632	928680
SF-11-C	928618	928667
SM-11-C	928619	928668
F-11-CT	860846	860855
M-11-CT	860847	860856

**Torque Limiter – T Option**

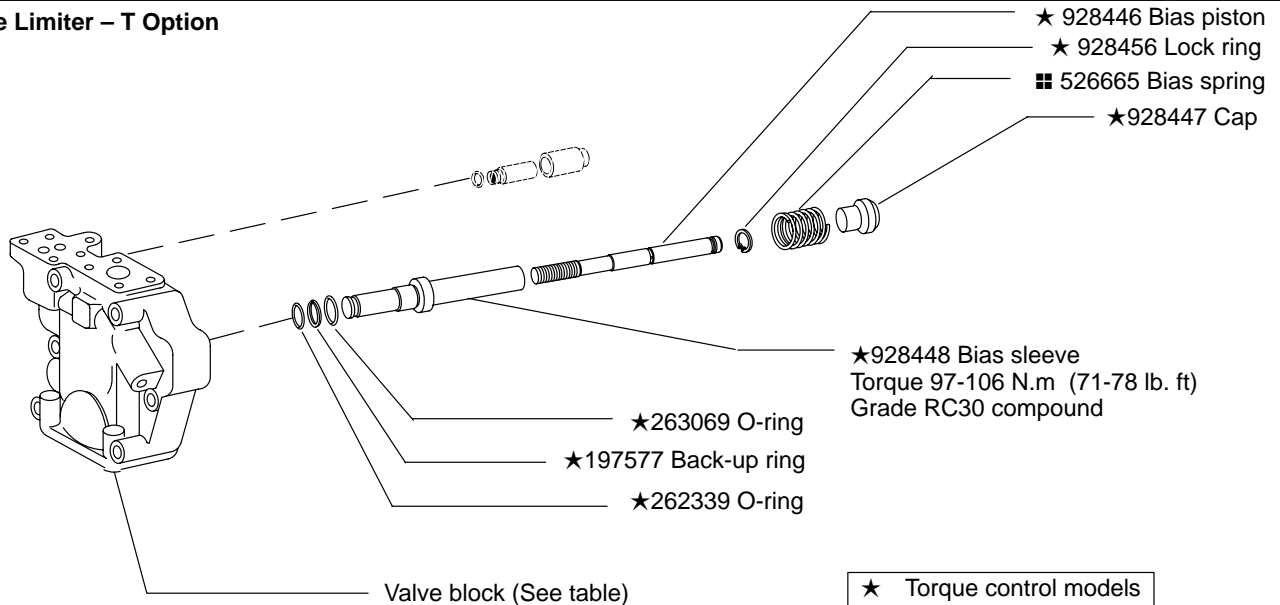

**Standard – C/CM/CMV/CV/IC**

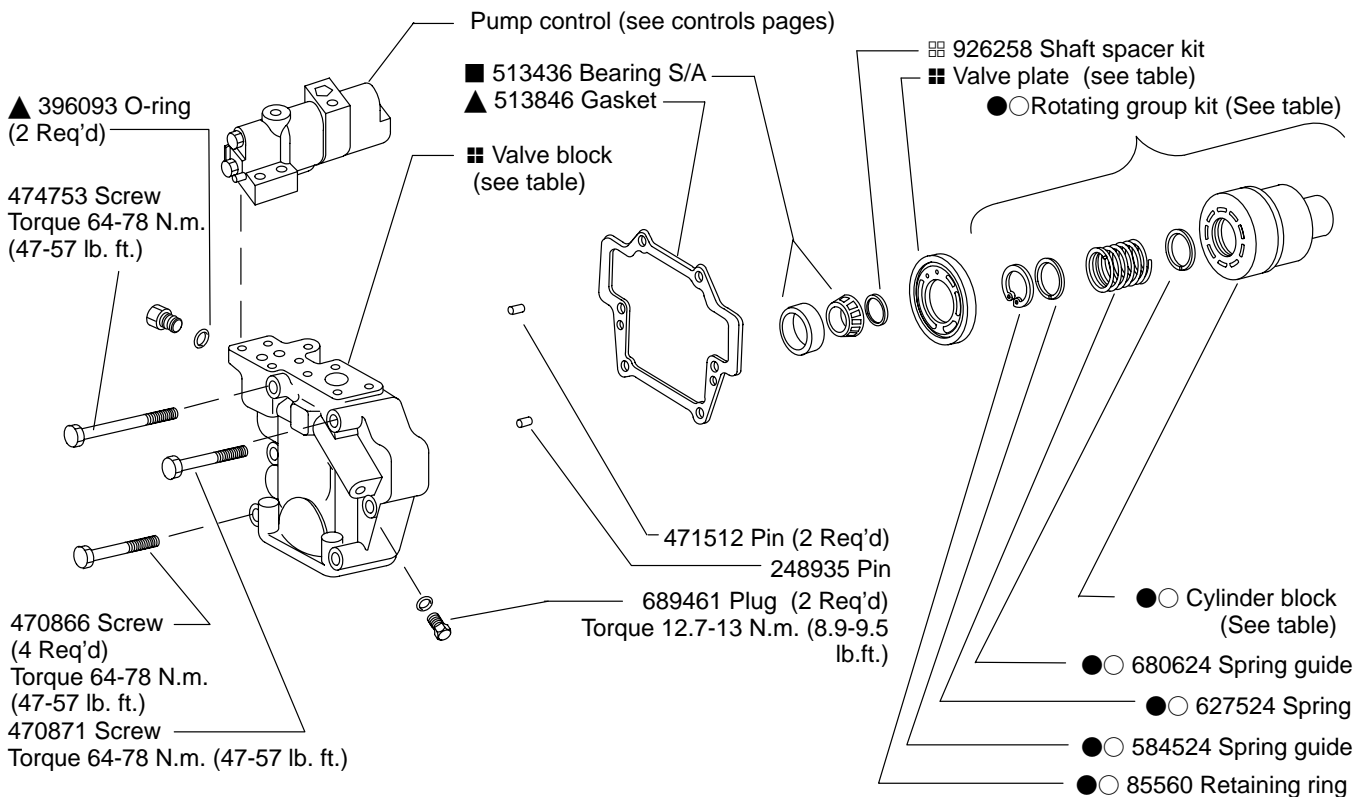

Housing	Flange/Seal
526614	-C-*S
864204	-C-*D
883084	-C2-*S
864313	-C2-*D
860808	-C3-*S
860815	-M-*S
864203	-130 suffix

Valve Plate Table		
Pump Type	RH	LH
57	680630	680631
57QI	514128	514121
57QP	913696	N/A
63	934442	934439
63QI	928579	860774
63QP	934443	N/A

**Note**  
Complete replacement via rotating group kits is recommended.

Model Designation	Piston & Shoe S/A (9 req'd)	Cylinder Block	Shoe Cage	Rotating Group Kit
●57 Size	02-306362	937023	584512	877420
○63 Size	02-306363	937024	860754	02-334358

Shaft	Type	Key
527166	1 – Straight keyed	114516
513839	2 – Splined	–
883083	N – Straight keyed	472287
864342	1 – Straight key (thru)	114516
526684	2 – Spline (thru)	–
913978	8 - Splined (130)	–

- 513433 Bearing S/A
- \* 513885 Saddle bearing
- \* 513886 Saddle bearing
- \* 690339 Screw (2 Req'd)  
Torque 3.6-4.4 N.m.  
(2.3-3 lb. ft.)

- \* 690832 Yoke S/A
- 690801 Spacer (2 Req'd)
- Shoe cage (See table)
- Rotating group kit (See table)
- 473741 Screw (4 Req'd)  
Torque 13-15 N.m. (9-11 lb. ft.)
- Shaft (See table)
- 690218 Limiter (2 Req'd)
- Piston & Shoe S/A (See table)
- ▲ 262355 O-Ring
- 690210 Control rod  
Torque 82-91 N.m. (60-67 lb. ft.)  
Grade RC30 compound
- 690211 Control piston
- ▲ 262355 O-Ring
- †■ 526685 Bias rod  
Torque 82-91 N.m. (60-67 lb. ft.)  
Grade RC30 compound
- 526665 Spring
- †■ 526668 Bias piston

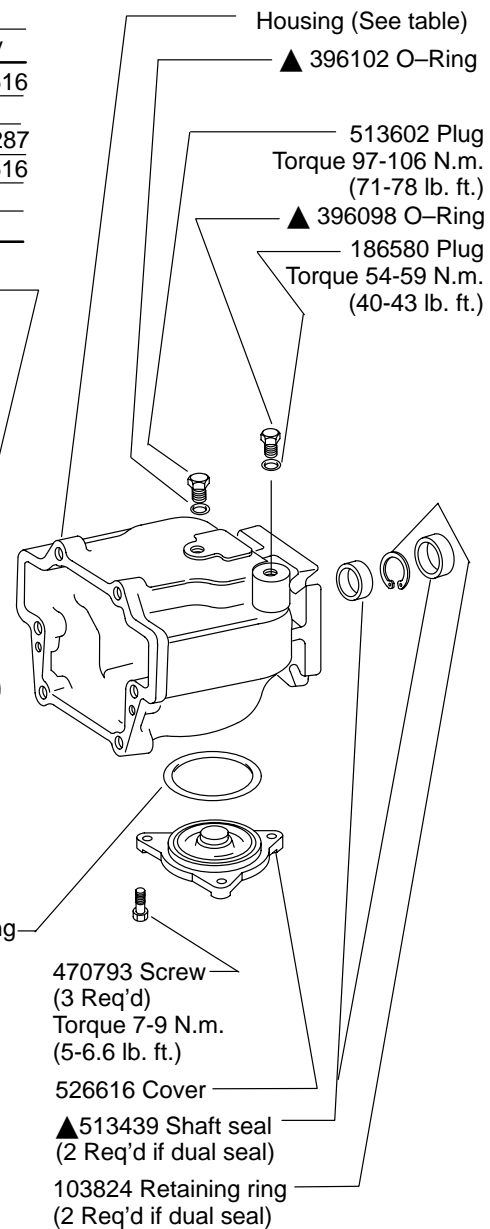

**NOTE**

Right hand rotation shown. View is opposite for left hand rotation. Please refer to Overhaul Manual M-2210-S.

**NOTE**

Use shims as required to obtain 0.01–0.10 mm (.0004–.004 in.) axial shaft end play.

**NOTE**

For satisfactory service life of these components in industrial applications, use full flow filtration to provide fluid which meets cleanliness code 16/14/12 or cleaner.

† Non-torque control models

- ▲ Available in double shaft seal kit 02-102244
- Available in bearing kit 877423
- \* Available in bearing/yoke kit 02-334832

- Available in PVH57 rotating group kit.
- Available in PVH63 rotating group kit.

**Load Sensing & Pressure Compensator Control C(M)\*V**

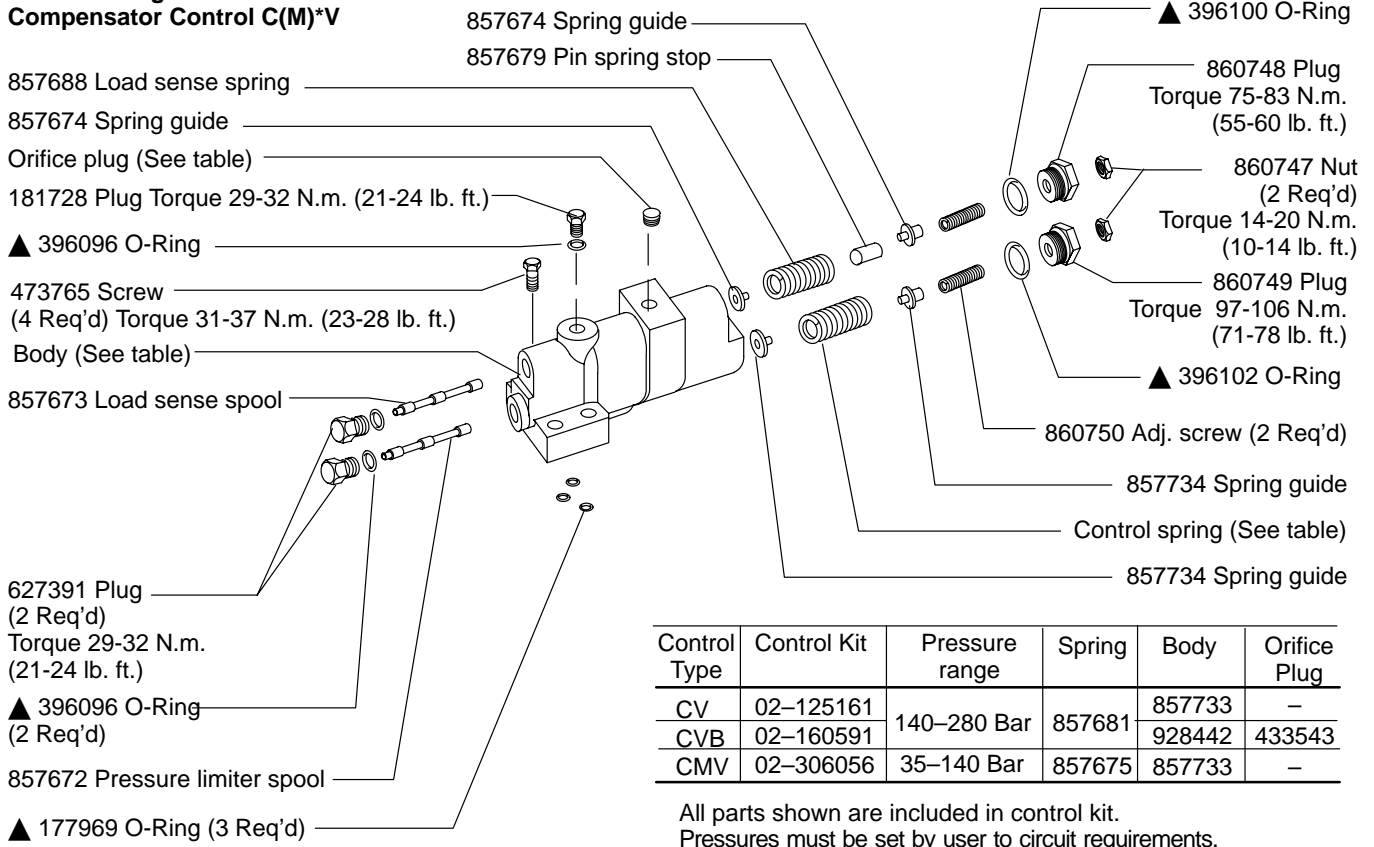

Control Type	Control Kit	Pressure range	Spring	Body	Orifice Plug
CV	02-125161	140-280 Bar	857681	857733	-
CVB	02-160591			928442	433543
CMV	02-306056	35-140 Bar	857675	857733	-

All parts shown are included in control kit.  
Pressures must be set by user to circuit requirements.

**Pressure Compensator Control C & CM**

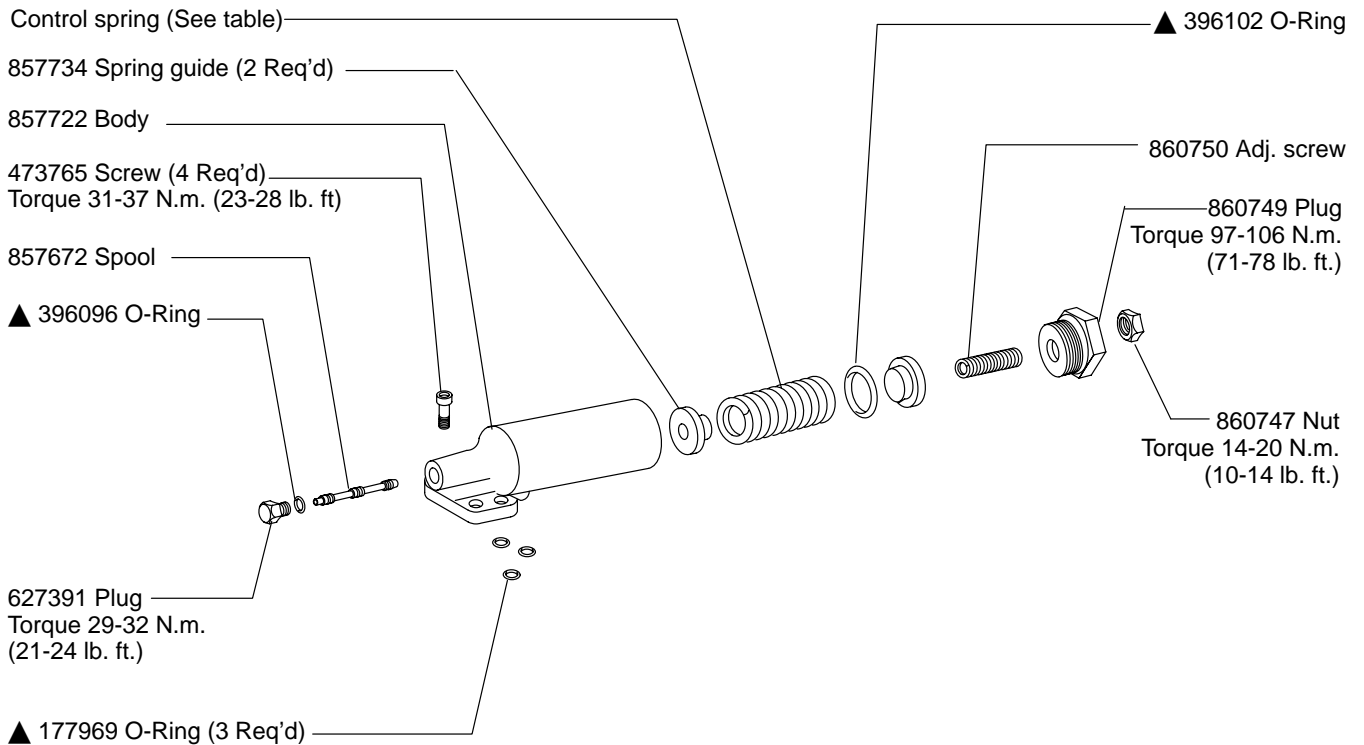

Control Type	Control Kit	Pressure range	Spring
C	02-125160	140-280 Bar	857681
CM	02-125162	35-140 Bar	857675

All parts shown are included in control kit.  
Pressures must be set by user to circuit requirements.

### Industrial Control (IC)

- 473769 Screw (2 Req'd)  
Torque 31-37 N.m. (23-28 lb. ft.)
- 407533 Plug  
Torque 12.1-12.4 N.m. (8.9-9.1 lb. ft.)
- ▲ 396093 O-Ring
- ▲ 396092 O-Ring (3 Req'd)
- 627391 Plug (3 Req'd)  
Torque 9.8-10.2 N.m. (7.2-7.5 lb. ft.)
- Body (see table)
- 857688 Spring
- 857679 Pin spring stop
- 857674 Spring guide (2 Req'd)
- ▲ 396100 O-Ring
- 860747 Nut  
Torque 14-20 N.m.  
(10-14 lb. ft.)
- 860750 Adj. screw
- 860748 Plug  
Torque 75-83 N.m. (55-60 lb. ft.)

Control Kit	Threads	Body
02-151904	inch	883386
02-151905	metric	860628

All parts shown are included in control kit. Pressures must be set by user to circuit requirements.

- (2 Req'd) Torque 31-37 N.m. (23-28 lb. ft.)
- 473765 Screw
- ◇ 113000 Plug  
Torque 5.1-5.9 N.m. (3.7-4.4 lb. ft.)
- 860566 Orifice plug  
Torque 1.7-2.3 N.m.  
(1.2-1.7 lb. ft.)
- ▲ 396096 O-Ring
- ◇ 181728 Plug  
Torque 29-32 N.m.  
(21-24 lb. ft.)
- 627391 Plug  
Torque 29-32 N.m.  
(21-24 lb. ft.)
- ▲ 396096 O-Ring
- 939816 Spool
- ▲ 177969 O-Ring  
(2 req'd)
- ▲ 216630 O-Ring

#### ◇ NOTE

IC kits pre-set to 20-30 bar differential pressure with all orifices/plugs in place. Reference Vickers Overhaul Manual M-2210-S for proper orifice/plug configuration in various circuits prior to control installation.

### Torque Limiter – T Option

- 928388 Guide
- Spring (See table)
- 857734 Guide
- 263069 O-ring
- 913453 Guide
- 473773 Screw (4 req'd)  
Torque to 31-37 N.m  
(42-50 lb. ft.)
- 197594 Back-up ring
- 262356 O-ring
- 860655 Plug Torque 75-83  
N.m (102-112 lb. ft.)
- ◆ 248823 Pin
- 186580 Plug  
Torque 54-59 N.m  
(73-80 lb. ft.)
- 263497 O-ring
- 113000 Plug  
Torque 15-17 N.m  
(20-23 lb. ft.)
- ◆ 932716 Connector  
Torque 54-59 N.m  
(73-80 lb. ft.)
- ◆ 263497 O-ring
- 860749 Plug  
Torque 75-83 N.m  
(102-112 lb. ft.)
- 860750 Adjusting Screw
- 860747 Nut  
Torque 8-10 N.m  
(11-14 lb. ft.)
- 1649 Ball
- 471627 Pin
- 937272 Check valve  
Torque 1.7-2.3 N.m  
(2.3-3.1 lb. ft.)
- 217669 O-ring
- 177969 O-ring  
(2 req'd)
- 913454 Spool
- 860653 Body
- 177969 O-ring (5 req'd)
- 577639 Sleeve
- 262356 O-ring
- 248845 Pin
- ◆ 932716 Retainer Ring  
(Screw into bottom of thread)

Model designation	Control Kit	Spring
T**-31	02-314944	857675
T**S-31	02-335254	857681

◆ Torque summation parts

### \*A\* Thru-drive

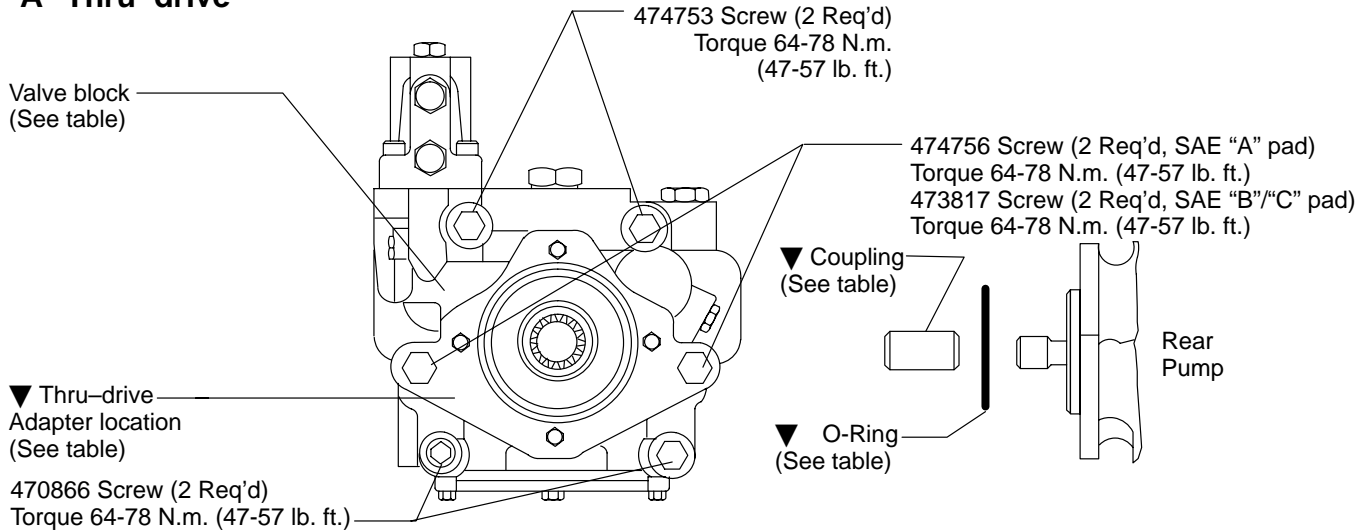

### "A" Thru-drive

Model designation	Valve block w/ SAE "A" Pad	O-Ring	Coupling Type
LAF-11-C*	928705	576601	864460 9 tooth SAE-A
LAM-11-C*	928706		
RAF-11-C*	928730		
RAM-11-C*	928731		
LAF-11-CT	860837		
LAM-11-CT	860838		
RAF-11-CT	860828		
RAM-11-CT	860829		

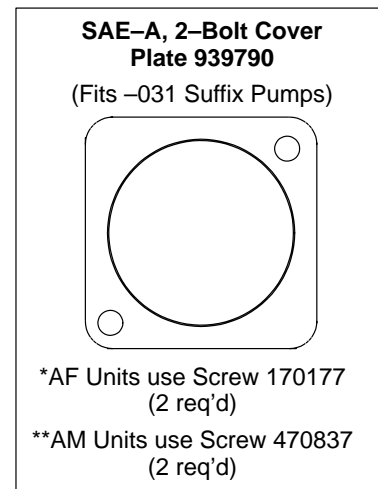

### ▼"B" & "C" Thru-drive Adapter

Model Designation	Adapter Pad Kit	Adapter Flange	O-Ring	Coupling Types
*-BF-11-*	876390	526670	401525	526694 SAE-B 13 tooth
*-BM-11-*	876394	876393		526695 SAE-BB 15 tooth
*-CF-11-*	876389	692934	353264	526696 SAE-C 14 tooth
*-CM-11-*	876392	876391		

#### Notes:

1. "F" type equal SAE threads
2. "M" type equal metric threads
3. "B" and "C" thru-drives created from "A" thru-drive pump with "B" or "C" thru-drive adapter kit installed.
4. All screws/O-rings are included with each "kit" to convert from "A" to "B" or "C" thru-drive unit.

## Typical Cross Section

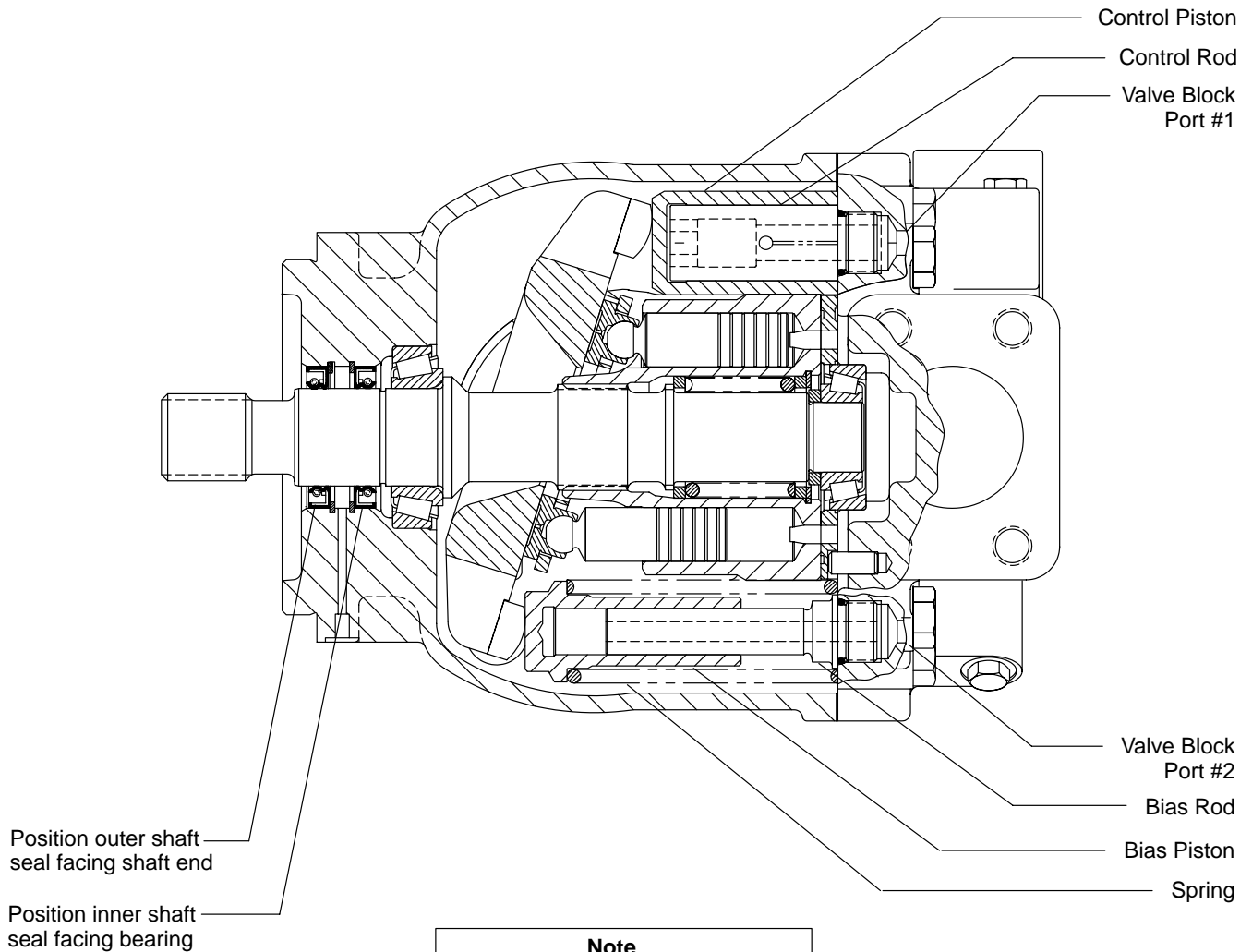

## Pump Startup

Make sure the reservoir and circuit are clean and free of dirt and debris prior to filling with hydraulic fluid.

Fill the reservoir with filtered oil to a level sufficient to prevent vortexing at suction connection to pump inlet. It is good practice to clean the system by flushing and filtering using an external slave pump.

Before starting the pump, fill with fluid through one of the ports. This is particularly important if the pump is above the fluid level of the reservoir.

When initially starting the pump, remove all trapped air from the system. This can be accomplished by loosening the pump outlet fittings or connections before starting the pump, or by using an air bleed valve. All inlet connections must be tight to prevent air leaks.

Once the pump is started, it should prime within a few seconds. If the pump does not prime, check to make sure that there are no air leaks in the inlet line and connections. Also check to make sure that trapped air can escape at the pump outlet.

After the pump is primed, tighten the loose outlet connections, then operate for five to ten minutes (unloaded) to remove all trapped air from the circuit. If reservoir has a sight gage, make sure the fluid is clear—not milky.

Add fluid to the reservoir up to the proper fill level.

# Model Code

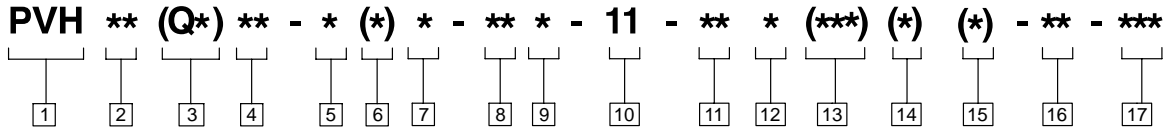

**1 Piston pump, variable displacement**

**2 Maximum geometric displacement**

**57** - 57.4 cm<sup>3</sup>/r (3.5 in<sup>3</sup>/r)  
**63** - 62.9 cm<sup>3</sup>/r (3.84 in<sup>3</sup>/r)

**3 Application style**

**Blank** - Mobile application (rated speed & 250/280 bar (3600-4000 psi) pressures)

**QI** - Quiet industrial application (1500 - 1800 rpm & 250/280 bar (3600-4000 psi) pressures)

**QP** - Quiet power unit application (1800 rpm & 140 bar (2000 psi) max. pressures – R.H. rotation only)

**4 Mounting flange, prime mover end**

**C** - SAE “C” 4-bolt type (SAE J744-127-4 )

**C2** - Optional combination 2- & 4-bolt SAE-C pilot

**C3** - Optional 4-bolt SAE-C pilot for vertical pump mounting

**M** - Optional metric 4-bolt pilot ISO 3019/2-125B4HW (Must be used with ‘N’ shaft option.)

**5 Shaft rotation, viewed at prime mover end**

**R** - Right hand, clockwise

**L** - Left hand, counterclockwise

**6 Configuration**

**Blank** - Non-thru-drive (single pump)

**A** - SAE-A thru-drive pump, standard (SAE J744-82-2)

**B** - SAE-B thru-drive pump, optional (SAE J744-101-2/4)

**C** - SAE-C thru-drive pump, optional (SAE J744-127-2/4)

**S** - Adjustable maximum volume stop (“S” option not available on thru-drive and torque control pump models.)

**7 Main ports**

**F** - SAE 4-bolt flange ports (standard)

**M** - SAE 4-bolt pads with metric mounting bolt threads

**8 Shaft-end type, at prime mover end**

**N** - Metric ISO short straight key (ISO 3019/2-E32N for “M” pilot only)

**1** - SAE-C straight key

**2** - SAE-C 14 tooth spline

**8** - SAE-BB, 15 tooth spline

**9 Shaft seal, prime mover end**

**S** - Single, one-way

**D** - Double, two-way

**10 Pump design number**

**11** - (Subject to change. Installation dimensions unaltered for design numbers 10 to 19 inclusive. )

**11 Pressure control type**

**C** - Compensator, 140-280 bar (2000-4000 psi)

**CM** - Compensator, 35-140 bar (500-2000 psi)

**IC** - CETOP 3 interface compensator, 20 bar factory “differential” pressure setting (QI and QP models only)

**12 Factory compensator pressure setting**

**Blank** - Leave blank for “IC” controls only  
**7** - 70 bar (1015 psi) normal “CM7” setting (all pump sizes)

**23** - 230 bar (3335 psi) normal “C23” setting (63, 81, 106, 141 models)

**25** - 250 bar (3625 psi) normal “C25” setting (57, 74, 98, 131 models)

**13 Optional pressure control functions**

**Blank** - Leave blank for basic compensator controls of IC models.

**V** - Load sensing, 20 bar (290 psi) factory “differential” pressure setting

**T** - Torque limiting control (Used with sections **14** and **15** .

**VT** - Load sensing with torque limiting

**VB** - Load sensing with internal bleed down (0.15” dia. orifice)

**VBT** - Load sensing with internal bleed down and torque limiting

**14 Torque limiting control pressure setting**

**Blank** - Leave blank if no torque limiting control is used

**4** - Standard minimum 40 bar setting of “T” torque control option

**15 Torque limiting control summation**

**Blank** - Standard torque control

**S** - Optional torque control with summation feature

**16 Control design number**

**31** - All control options

**17 Special feature suffix**

**031** - Mounting with SAE-A, 2-bolt cover plate

**130** - PVH57/63 with SAE-B, 4.00 inch dia. pilot, 2/2-bolt mount. Both 2-bolt patterns are rotated 45 degrees from port center line.