

Vane Pumps



Double Vane Type Pump

(F3)-V2020*-*(*)F*S*S-1**-**-30(L)

MODEL CODE	PRESSURE SETTING	CONTROL VALVE S/A (F Cover Only)
A –	250 psi	229613
B –	500 psi	233018
C –	750 psi	232794
D –	1000 psi	232795
E –	1250 psi	232796
F –	1500 psi	232797
G –	1750 psi	232798
H –	2000 psi	232799
J –	2250 psi	233019
K –	2500 psi	233020

NOTE
For satisfactory service life of these components in industrial applications, use full flow filtration to provide fluid which meets ISO cleanliness code 16/13 or cleaner. OFF, OFR, and OFRS series filters are recommended.

MODEL	COVER
V2020-****S-**	850557
V2020F****P-**2	850601
V2020F****S-**2	850584
V2020F****T-**2	850563
V2020P****T-***2	850309

F – Flow Control

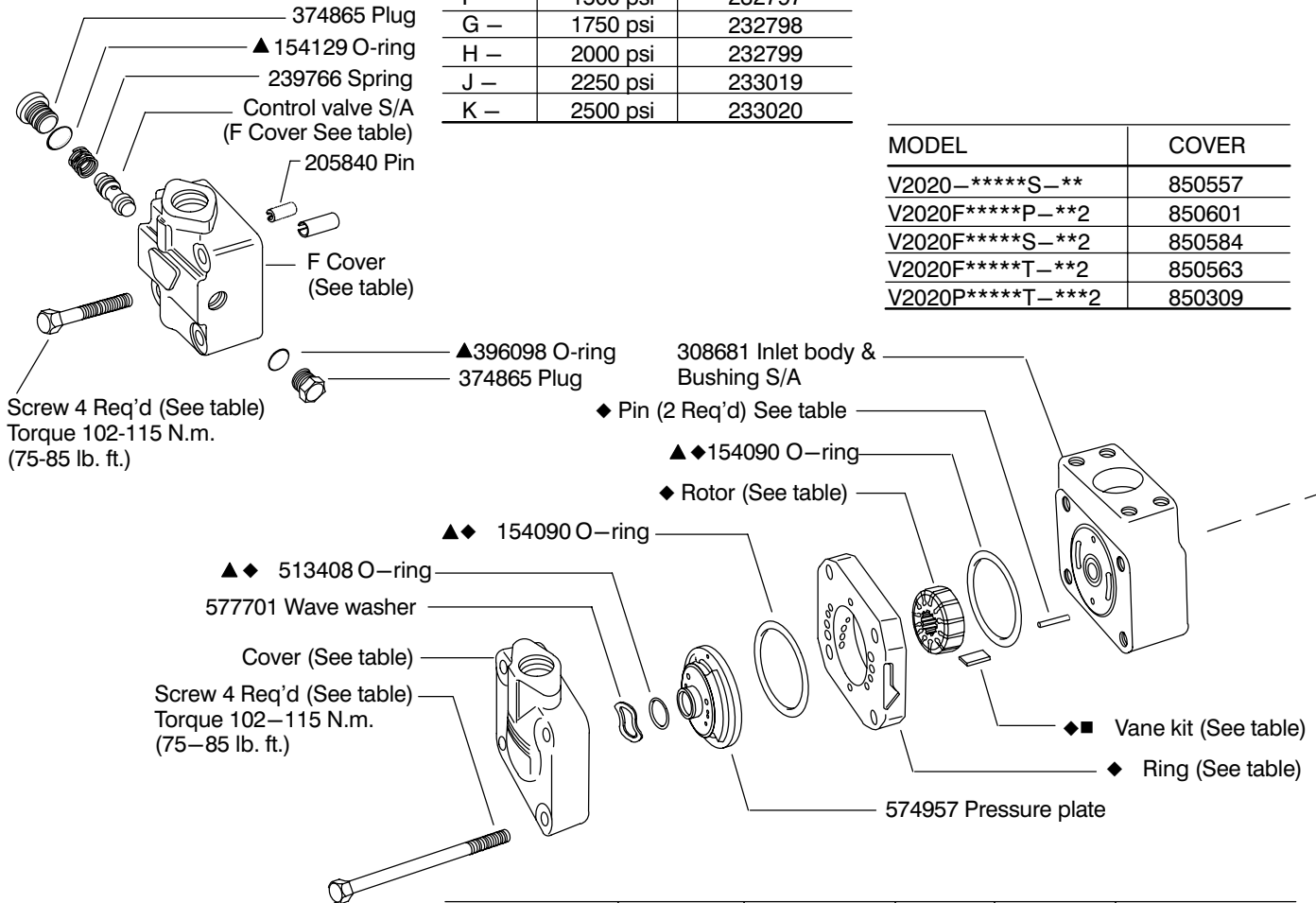

P – Priority Control

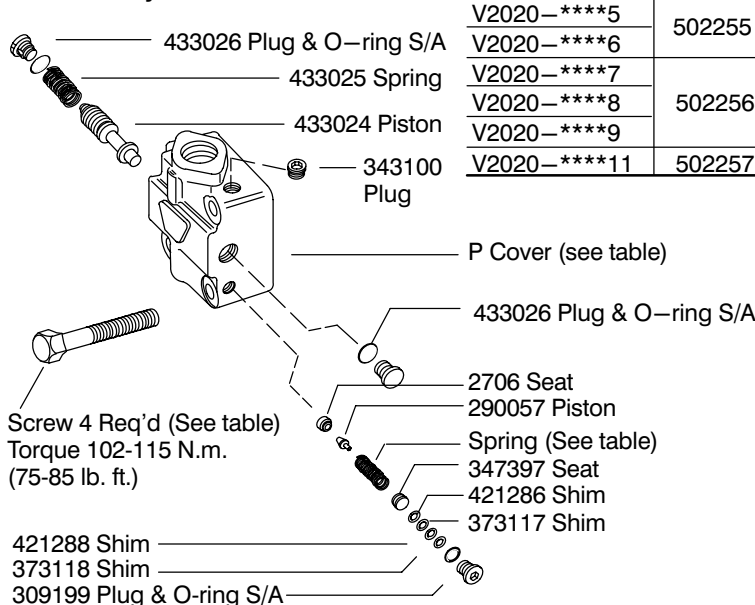

MODEL	◆ ROTOR	◆ VANE KIT	◆ PIN	◆ RING	◆ COVER END CART. KIT
V2020-****5	502255	923485	2456	388284	02-141747
V2020-****6				328150	923480
V2020-****7	502256	923493	16662	328152	923481
V2020-****8				331791	923483
V2020-****9				331789	923484
V2020-****11	502257	923478	179341	328156	923482

MODEL	PRESSURE SETTING	SPRING
V2020P-****-A	250 psi	252886
V2020P-****-B	500 psi	2280
V2020P-****-C	750 psi	
V2020P-****-D	1000 psi	435626
V2020P-****-E	1250 psi	
V2020P-****-F	1500 psi	
V2020P-****-G	1750 psi	2281
V2020P-****-H	2000 psi	
V2020P-****-J	2250 psi	
V2020P-****-K	2500 psi	

NO.	SHAFT	KEY	NUT	TYPE
1	308686	9955	—	Straight
3	308925	1617	18755	Threaded
11	308926	—	—	Splined

MODEL	BODY
V2020-1**S	850224
V2020-6**S	849819

849807 Wave washer
(Install before O-ring)

▲ 200142 O-ring

849818 Pressure plate

▲ ● 154090 O-ring

● Pin (2 Req'd) See table

●■ Vane kit (See table)

● Rotor (See table)

● Ring (See table)

Shaft (See table)

140356 Ret. ring

Nut (See table)

Key (See table)

82938 Bearing

160686 Retaining ring

452556 Washer

▲ 229236 Shaft seal

NOTE

Shaft seal must be assembled with solid side flush to .005 below bearing bore.

MODEL	● ROTOR	●■ VANE KIT	● PIN	● RING	● SHAFT END CART. KIT
V2020-**5**	388286	923485	2456	388284	02-141745
V2020-**6**				328150	02-141746
V2020-**7**	358335	923493	16662	328152	923494
V2020-**8**				331791	923495
V2020-**9**				331789	923462
V2020-**11**	358336	923478	179341	328156	923475
V2020-**12**				331806	923476
V2020-**13**	358337	923479	7688	331807	923477

RING COMBINATIONS		Screw	Cover
Shaft End	Cover End		
5 & 6	7	189378	Std.
7	5 & 6		
9	6		
8	7		
8	8	142713	Std.
11	11		
12	8		
13	9		
5 & 6	12 & 13	36048	F
10 & 11	7, 8 & 9		
12 & 13	5 & 6		
11	10 & 11	73074	F
12 & 13	7, 8 & 9		
12 & 13	10 & 11		
5 & 6	10 & 11	134249	F
7, 8 & 9	7, 8 & 9		
10 & 11	5 & 6		
5 & 6	7, 8 & 9	142713	F
7, 8 & 9	5 & 6		
10 & 11	7, 8 & 9	36048	P
12 & 13	6		
10 & 11	11	73074	P
12 & 13	7, 8 & 9		
12 & 13	11		
7, 8 & 9	7, 8 & 9	134249	P
10 & 11	6		
7, 8 & 9	6	142713	P

- ▲ Included in seal kit 02-143191
F3 equivalent seal kit 02-143192
- Shaft end cartridge kit (See table)
- ◆ Cover end cartridge kit (See table)
- Vane kit (includes 12 vanes) See table

Model Code

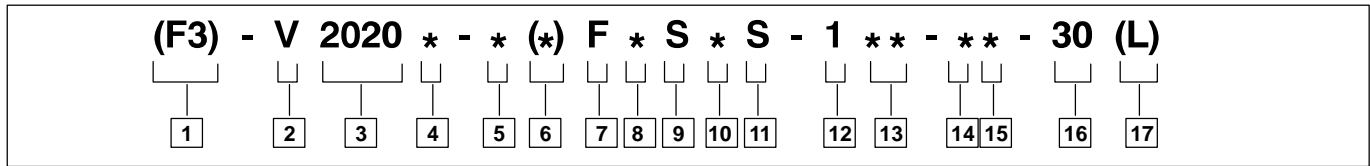

1 Special seals
F3 - For mineral oil & fire resistant fluids
 (Omit if not required)

2 Vane pump

3 Series designation

4 Cover type

F - Flow control cover
P - Priority valve cover
Omit - Standard cover

5 Mounting

1 - Flange, 2 bolt SAE B size
2 - Foot bracket
6 - Flange, 2 bolt SAE A size

6 Foot bracket

(Mounting position with respect to inlet port when viewed from shaft end. No code required for inlet port at 12 o'clock)

3 - Inlet port at 3 o'clock
6 - Inlet port at 6 o'clock
9 - Inlet port at 9 o'clock
 Omitted for flange mounting

7 Inlet port

F - 4 bolt flange

8 Ring capacity (Shaft end)

(Rated capacity (USgpm) at 1200 rpm, 6.9 bar (100 psi))

5 - 5 USgpm **9** - 9 USgpm
6 - 6 USgpm **11** - 11 USgpm
7 - 7 USgpm **12** - 12 USgpm
8 - 8 USgpm **13** - 13 USgpm

9 No. 1 outlet port (Shaft end)

S - 1.062 - 12 UN-2B thread

10 Ring capacity (Cover end)

(Rated capacity (USgpm) at 1200 rpm, 6.9 bar (100 psi))

5 - 5 USgpm **8** - 8 USgpm
6 - 6 USgpm **9** - 9 USgpm
7 - 7 USgpm **11** - 11 USgpm

11 No. 2 outlet port (Cover end)

Code	Std. cover	Flow control cover	
		Pressure	Tank
P	—	3/4-16 St.Thd.	1/2 NPT Thd.
S	1.062-1 2	3/4-16 St.Thd.	1.062-12 St.Thd.
T	St.Thd.	3/4-16 St.Thd.	3/4-16 St.Thd.

Priority valve cover

Code	Primary outlet	Secondary outlet	Tank
T	3/4-16 St.Thd.	7/8-14 St.Thd.	3/4-16 St.Thd.

12 Shaft type

1 - Straight thread
3 - Threaded
11 - Splined

13 Outlet port orientation
 (Viewed from cover end of pump)

With no. 1 outlet opposite inlet

AA - No. 2 outlet opposite inlet
AB - No. 2 outlet 90° CCW from inlet
AC - No. 2 outlet inline with inlet
AD - No. 2 outlet 90° CW from inlet

With no. 1 outlet 90° CCW from inlet

BA - No. 2 outlet opposite inlet
BB - No. 2 outlet 90° CCW from inlet
BC - No. 2 outlet inline with inlet
BD - No. 2 outlet 90° CW from inlet

With no. 1 outlet inline with inlet

CA - No. 2 outlet opposite inlet
CB - No. 2 outlet 90° CCW from inlet
CC - No. 2 outlet inline with inlet
CD - No. 2 outlet 90° CW from inlet

With no. 1 outlet 90° CW from inlet

DA - No. 2 outlet opposite inlet
DB - No. 2 outlet 90° CCW from inlet
DC - No. 2 outlet inline with inlet
DD - No. 2 outlet 90° CW from inlet

14 Flow rate
 (Thru orifice in cover USgpm)

15 Pressure setting

A - 250 psi **F** - 1500 psi
B - 500 psi **G** - 1750 psi
C - 750 psi **H** - 2000 psi
D - 1000 psi **J** - 2250 psi
E - 1250 psi **K** - 2500 psi

16 Design

17 Rotation
 (Viewed from shaft end of pump)

L - Left hand (counterclockwise)
Omit - Right hand (clockwise)

Typical Sectional View

