

Service Data

Vickers®

Vane Pumps



Double Vane Type Pump

(F3)-V2010*-*(*)F*S*S-1**-12(L)



Table 1

Model	Cover
V2010-****P	372863
V2010-****R	372864
V2010-****S	372865
V2010F-****P-***-2†	379543
V2010F-****T-***-2†	372851
V2010P-****K-***-1‡	388262

†, ‡ See table 3

Table 2

Model Code	Pressure Setting	Control Valve S/A (F Cover only)	Spring (P Cover only)
A-	250 psi	229613	252886
B-	500 psi	233018	2280
C-	750 psi	232794	
D-	1000 psi	232795	2282
E-	1250 psi	232796	2281
F-	1500 psi	232797	
G-	1750 psi	232798	
H-	2000 psi	232799	
J-	2250 psi	233019	
K-	2500 psi	233020	

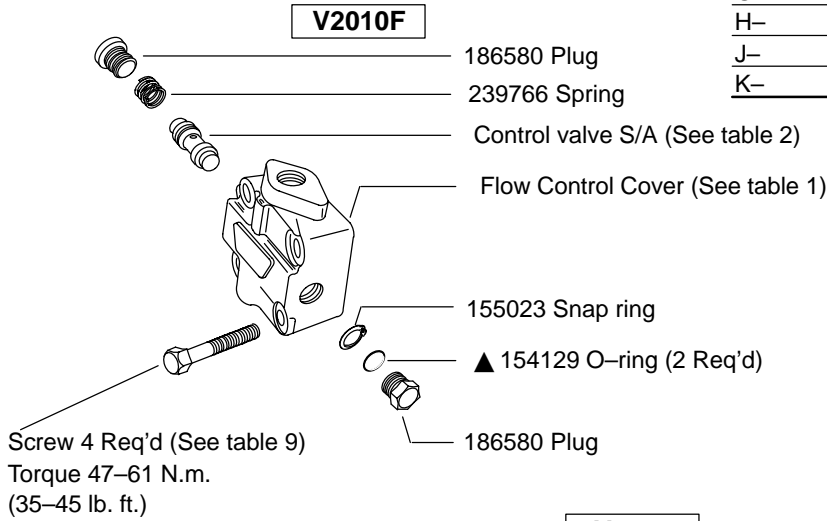

V2010

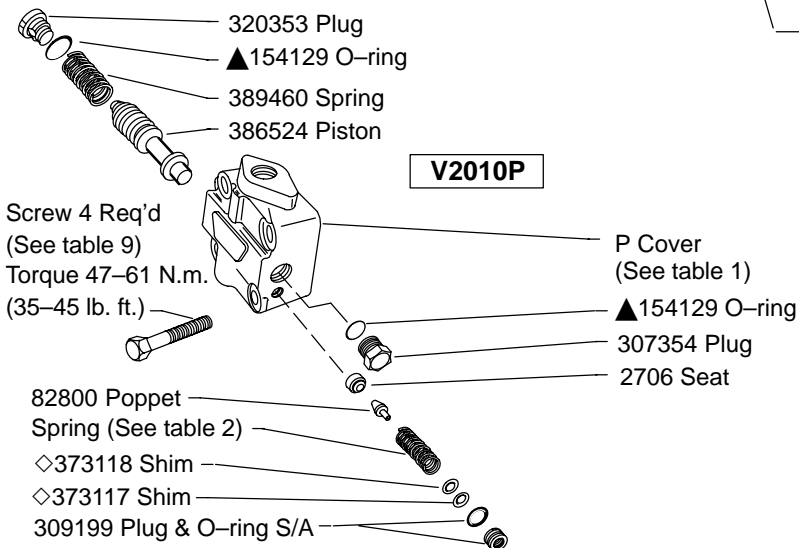
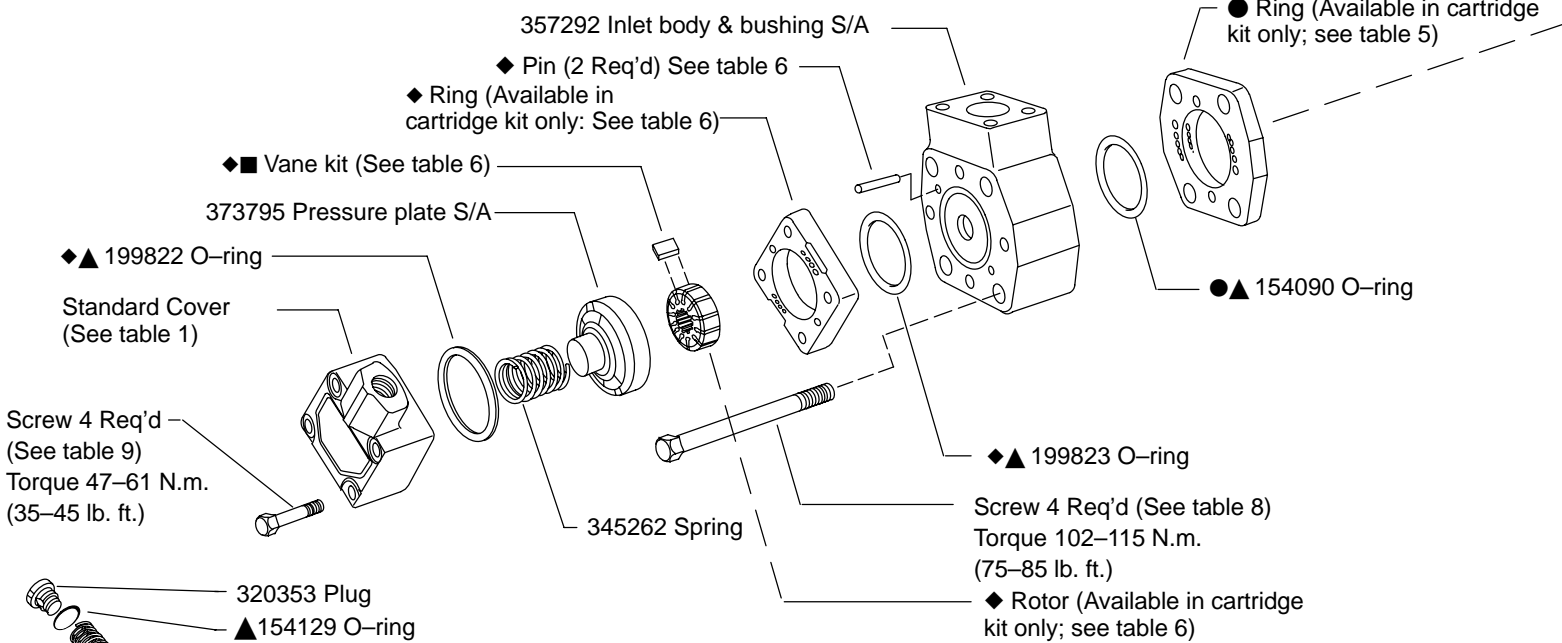

Table 3

V2010F & V2010P Cover Orifices		
USgpm thru	Orifice (Drill) Size	
Cover Orifice	V2010F†	V2010P‡
1	–	–
2	–	.1040"
3	.120" (#31)	.1285"
4	.136" (#29)	.1470"
5	.154" (#23)	.1610"
6	.169" (#18)	.1800"
7	.180" (#15)	.1935"
8	.193" (#10)	–
10	.2188	–

Table 4

Model	Body (Outlet #1)
V2010(*)-1*S	850224
V2010(*)-6*S	849819

Table 7

Model	Shaft	Key	Nut	Type
V2010(*)-*****-1	351249	9955		Straight
V2010(*)-*****-3	321214	1617	18755	Threaded
V2010(*)-*****-11	321215			Splined

▲ 229236 Shaft seal
(Shaft seal must be assembled with solid side flush to .005 below bearing bore)

849807 Wave washer
(Install before O-ring)
913569 Pressure plate

●▲ 154090 O-ring

160686 Ret. ring

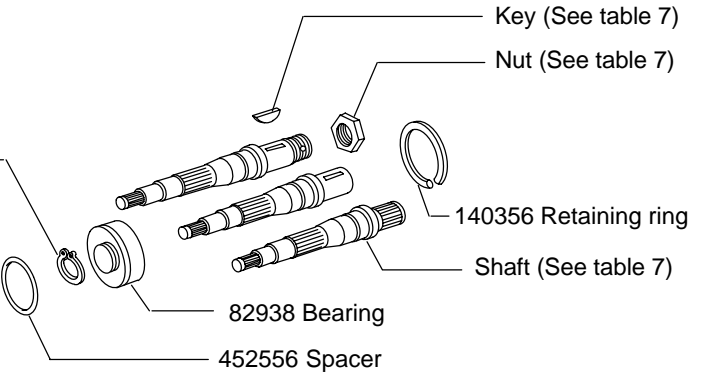

Body (See table 4)

▲ 200142 O-ring

● Pin (2 Req'd) See table 5

●■ Vane kit (See table 5)

● Rotor (Available in cartridge kit only; see table 5)

Table 8

Shaft End Ring Size	Screw
5 or 6	9431
7, 8 or 9	96168
10, 11, 12 or 13	295384

Table 5

Model	●■ Vane Kit	● Pin	● Cart. Kit (Shaft end)
V2010(*)-**5	923485	2456	02-141745
V2010(*)-**6			02-141746
V2010(*)-**7			02-152006
V2010(*)-**8	923493	16662	02-152007
V2010(*)-**9			02-152008
V2010(*)-**10			02-152009
V2010(*)-**11	923478	179341	02-152010
V2010(*)-**12			02-152011
V2010(*)-**13			02-152012

Table 6

Model	●■ Vane Kit	● Pin	● Cart. Kit (Shaft end)
V2010(*)-****1	923499	231042	923471
V2010(*)-****2			923470
V2010(*)-****3			923496
V2010(*)-****4	923500	2456	923469
V2010(*)-****5			923468
V2010(*)-****6			923497
V2010(*)-****7	923501	351963	923498

Table 9

Cover End Ring Size	Screw	Cover
1, 2 or 3	1277	Std.
4 or 5	108561	
6 or 7	1278	
1, 2 or 3	1278-B	F
4 or 5	1278-C	
6 or 7	1278-A	
1, 2 or 3	1278-C	P
4 or 5	1278-A	
6 or 7	107889	

▲ Included in seal kit 923577
(F3 equivalent seal kit 919770)

● Included in shaft end cartridge kit
(See table 5)

◆ Included in cover end cartridge kit
(See table 6)

■ Vane kit (includes 12 vanes) See
tables 5 & 6

◇ Included in shim kit 941038

NOTE:

For satisfactory service life of these components in industrial applications, use full flow filtration to provide fluid which meets ISO cleanliness code 16/13 or cleaner. OFP, OFR, and OFRS series filters are recommended.

Model Code

(F3) - V 2010 * - * (*) F * S * S - 1 ** - 12 (L)

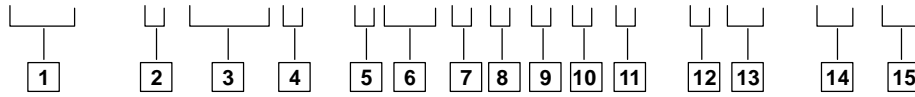

1 Special seals

2 Vane pump

3 Series designation

4 Cover type

F – Flow control cover
P – Priority valve cover
Omit – Standard cover

5 Mounting

1 – Flange, 2 bolt SAE B size
2 – Foot bracket
6 – Flange, 2 bolt SAE A size

6 Foot bracket

(Mounting position with respect to inlet port when viewed from shaft end. No code required for inlet port at 12 o'clock)

3 – Inlet port at 3 o'clock
6 – Inlet port at 6 o'clock
9 – Inlet port at 9 o'clock
Omitted for flange mounting

7 Inlet port

F – 4 bolt flange, 1.500 dia.

8 Ring capacity (Shaft end)

(Rated capacity (USgpm) at 1200 rpm, 6.9 bar (100 psi))

7 – 7 USgpm 11 – 11 USgpm
8 – 8 USgpm 12 – 12 USgpm
9 – 9 USgpm 13 – 13 USgpm

9 No. 1 outlet port (Shaft end)

S – 1.062 – 12 UN–2B thread

10 Ring capacity (Cover end)

(Rated capacity (USgpm) at 1200 rpm, 6.9 bar (100 psi))

1 – 1 USgpm 7 – 7 USgpm
2 – 2 USgpm 5 – 5 USgpm
3 – 3 USgpm 6 – 6 USgpm
4 – 4 USgpm

11 No. 2 outlet port (Cover end)

Code	Std. cover	Flow control cover	
		Pressure	Tank
P	1/2 NPT Thd.	3/4–16 St.Thd.	1/2 NPT Thd.
R	1.062–12 St.Thd.	_____	_____
S	3/4–16 St.Thd.	_____	_____
T	_____	3/4–16 St.Thd.	3/4–16 St.Thd.

12 Shaft type

1 – Straight thread
3 – Threaded
11 – Splined

13 Outlet port orientation

(Viewed from cover end of pump)

With no. 1 outlet opposite inlet

AA – No. 2 outlet 135° CCW from inlet
AB – No. 2 outlet 45° CCW from inlet
AC – No. 2 outlet 45° CW from inlet
AD – No. 2 outlet 135° CW from inlet

With no. 1 outlet 90° CCW from inlet

BA – No. 2 outlet 135° CCW from inlet
BB – No. 2 outlet 45° CCW from inlet
BC – No. 2 outlet 45° CW from inlet
BD – No. 2 outlet 135° CW from inlet

With no. 1 outlet inline with inlet

CA – No. 2 outlet 135° CCW from inlet
CB – No. 2 outlet 45° CCW from inlet
CC – No. 2 outlet 45° CW from inlet
CD – No. 2 outlet 135° CW from inlet

With no. 1 outlet 90° CW from inlet

DA – No. 2 outlet 135° CCW from inlet
DB – No. 2 outlet 45° CCW from inlet
DC – No. 2 outlet 45° CW from inlet
DD – No. 2 outlet 135° CW from inlet

14 Design

15 Rotation

(Viewed from shaft end of pump)

L – Left hand (counterclockwise)
Omit – Right hand (clockwise)

Typical Sectional View

